

StudioComm for Surround

Model 76DBA Central Controller and Model 77B Control Console

User Guide

Issue 1, November 2010

**This User Guide is applicable for systems consisting of:
Model 76DBA: serial number M76DBA-00151 and later with software version 3.00 and higher;
Model 77B: serial number M77B-00210 and later with software version 3.00 and higher**

© 2010 by Studio Technologies, Inc., all rights reserved
www.studio-tech.com

This page intentionally left blank.

Table of Contents

Introduction.....	5
Installation	9
Configuration	19
Operation.....	37
Technical Notes	45
Specifications	49
Appendix A—Connection Pin-Out Charts	51
Appendix B—Sync Sources	52

This page intentionally left blank.

Introduction

What This User Guide Covers

This User Guide is designed to assist you when installing and using the Model 76DBA Central Controller and one or more associated Model 77B or Model 71 Control Consoles.

Overview

As creating and distributing multi-channel surround (5.1) and stereo audio material has become a day-to-day reality, the ability to simply and effectively monitor these sources is imperative for recording, post-production, and broadcast facilities. And with audio-with-picture applications becoming so prevalent, additional monitoring challenges have arisen. Studio Technologies has addressed these needs with the StudioComm for Surround Model 76DBA Central Controller and the Model 77B and Model 71 Control Consoles. With digital audio inputs, digital and analog monitor outputs, Dolby® E dialnorm support, and an extensive set of operating resources it's a simple task to integrate a monitoring system into virtually any facility. The carefully selected group of features, including flexible input source selection, configurable input-signal time delay, multiple digital and analog monitor outputs, downmix and solo functions, dialnorm display, along with a multi-format sync input, make the system powerful yet simple to operate. And by using the best of contemporary technology, as well as following rigorous design practices, the system's audio quality is excellent. Its unique feature set makes it especially well suited to meet the needs of broadcast master control applications.

A StudioComm for Surround system starts with the Model 77B Control Console. It's the system's "command center" and is designed to reside at an operator's location, allowing fingertip selection of all monitoring functions. Numerous LED indicators provide complete status information. A 4-digit numeric display indicates the post-fader monitor output level or dialnorm level in real time. A major strength of the Model 77B is its ability to configure, under software control, many important operating parameters. Intended for secondary monitoring locations, the Model 71 Control Console is a compact user control surface. It provides three of the most basic functions: a rotary level control, dim on/off button, and reference level on/off button.

While many installations will use only one Model 77B Control Console, up to three additional Model 77B or Model 71 Control Consoles can also be connected. This provides multiple users with full control over a facility's monitor system. And to make installation simple, the Model 76DBA provides power for all connected Model 77B or Model 71 units.

The core of this StudioComm for Surround system is the Model 76DBA Central Controller. The one-rack-space unit contains digital audio input, digital and analog monitor output, processing, and support circuitry. The Model 76DBA provides two surround (5.1) and three stereo digital audio inputs. These unbalanced digital inputs are AES3id/SMPTE 276M-compliant; sources of this type are ubiquitous in most post-production and broadcast environments. The inputs allow a sample rate of up to 192 kHz and a bit depth of up to 24 to be directly supported. Circuitry associated with one of the stereo inputs provides sample rate conversion

(SRC) capability, allowing a wide range of digital audio sources to be monitored. Up to 340 milliseconds of input delay can be selected to compensate for processing delays in an associated video path. A number of different signals can serve as the Model 76DBA's digital audio timing reference. For synchronization with a master timing reference a dedicated source of word clock, DARS (AES11), bi-level video, or tri-level video can be connected. Alternately, the L/R connection of the actively selected surround or stereo input source can serve as the timing reference.

A range of digital and analog surround (5.1) and stereo monitor outputs are provided. The post-fader surround digital and analog monitor outputs are intended for connection to monitor loudspeaker systems. The pre-fader surround digital monitor output can be used with metering systems that require signals that aren't impacted by level control or other monitoring

functions. The auxiliary stereo digital and analog outputs are provided for special broadcast applications where independent outputs with separate on/off control are desired. The stereo input C direct digital monitor output allows an installation to directly access the SRC capabilities.

For installation flexibility the digital monitor outputs can be configured for compatibility with equipment that requires AES3 ("balanced") or AES3id ("unbalanced") digital audio signals. When selected for AES3 compatibility the output impedance is 110 ohms with a signal level of 5 volts peak-to-peak (Vpp). For AES3id operation the impedance is 75 ohms and the level is 1 Vpp.

A source of Dolby E metadata can be connected to the Model 76DBA Central Controller. This RS-485/RS-422 115.2 Kbit/s serial data signal carries numerous data elements, including one that represents the average dialog level of an associated

Figure 1. Model 76DBA Central Controller Front Panel

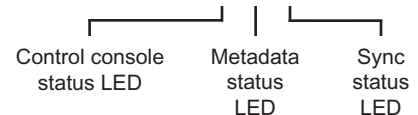
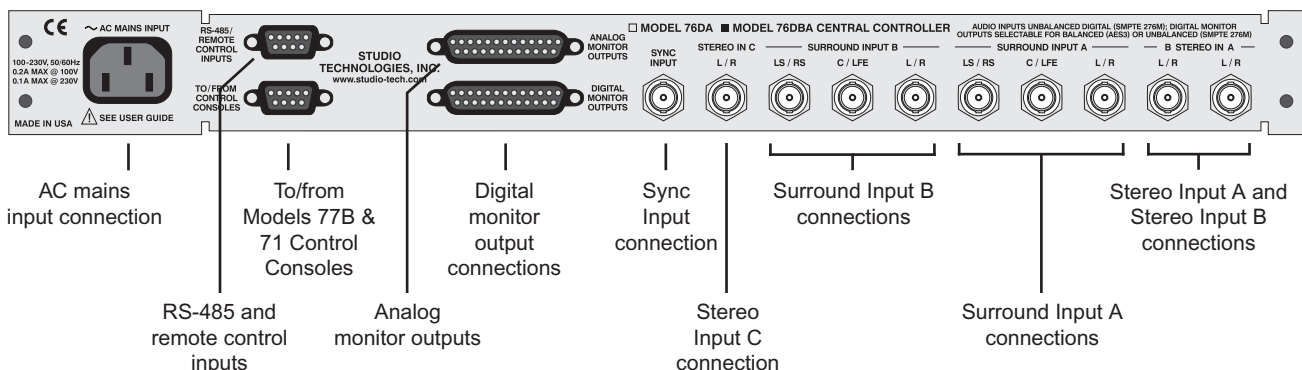

Figure 2. Model 76DBA Central Controller Back Panel



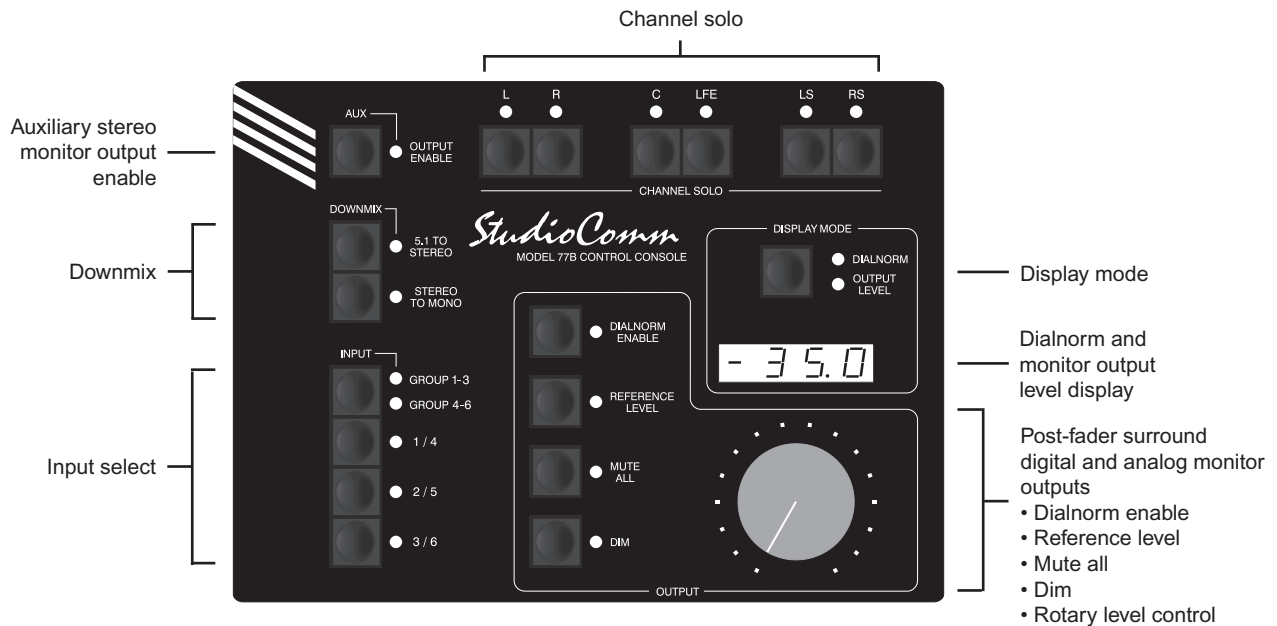

Figure 3. Model 77B Control Console Front Panel

audio program. This dialog normalization or “dialnorm” value is an integral part of many broadcast distribution systems, ending up as part of consumer audio playback systems. Hardware and software within the Model 76DBA separates the dialnorm element that relates to one of the connected surround audio sources. This dialnorm level value can be displayed on the Model 77B Control Console, as well as being used to automatically adjust the post-fader surround digital and analog monitor output levels. This provides a unique solution for the broadcast and post-production world, allowing a professional environment to accurately simulate an end user’s experience.

Great care was taken in designing the system’s architecture, ensuring that the character of the audio input signals is preserved. All audio processing is performed in 32 bits using a high-speed field-programmable gate array (FPGA) integrated circuit.

The Model 76DBA occupies one space (1U) in a standard 19-inch rack. Digital audio sources are interfaced with the Model 76DBA using nine BNC connectors. A tenth BNC connector is used by the sync source. Digital and analog monitor output signal connections are made using two 25-pin D-subminiature connectors. One 9-pin D-subminiature connector is used to connect the Model 76DBA with up to four Model 77B or Model 71 Control Consoles. A second 9-pin “D-sub” connector is used to interface Dolby E dialnorm data and remote control signals. AC mains power is connected directly to the Model 76DBA, with an acceptable range of 100 to 230 volts, 50/60 Hz.

Additional Details

The Model 77B provides four buttons and associated LEDs for selecting the input source to be monitored. The buttons are designed such that up to six unique input choices are available. Using the Model

77B's configuration mode, each of the six input choices can be configured from the system's two surround (5.1) and three stereo inputs. The configuration mode also allows stereo inputs A and B to be used as either stereo or monaural sources. This is especially useful in broadcast applications where a 2-channel AES3id source may carry two independent monaural signals. To highlight this powerful feature: the Model 77B allows independent monitoring of the two channels associated with a single AES3id source. Broadcast master control applications can greatly benefit from this configuration flexibility.

The post-fader surround digital and analog monitor output levels can be controlled by way of a large, easy-to-use rotary control. The control, actually a digital encoder, allows level selection in precise 0.5-dB steps. The auto mute all function causes the post-fader surround digital and analog monitor output channels to automatically mute whenever the output level control reaches maximum attenuation. Using the reference level function, the post-fader surround digital and analog monitor output levels can be set to a pre-configured value. This is provided for audio-with-picture applications that require a specific monitor output level. The reference level is easily configured by taking an electronic "snapshot" of the desired monitor output level. For operator confirmation a 4-digit LED readout can display the level of the post-fader surround digital and analog monitor output channels. To match the needs of a facility, it can be configured to display either the attenuation level or the sound pressure level (SPL).

The dim function allows the post-fader surround digital and analog monitor output levels to be reduced by a fixed dB amount.

The dim level is configured from among four available values. A mute all function allows the post-fader surround digital and analog monitor output channels to be simultaneously muted. The channel solo section provides post-fader surround digital and analog channel monitoring control, allowing a single channel to be monitored while the others are automatically muted. Multiple channels can also be simultaneously selected for "soloing."

A special solo mode is also provided, called channel pop solo, which offers a unique aid in monitoring audio material. Channel pop solo allows the level of a single post-fader surround digital and analog monitor output channel to be raised while the level of the other channels is reduced. This helps to emphasize the content on one channel without fully muting the others. Broadcast applications can benefit from the channel pop solo mode by allowing, for example, the center channel to be highlighted while still maintaining some level on the other channels. The amount of level increase—the "pop"—as well as the amount of attenuation can be configured to meet the needs of specific applications or users.

Two functions allow the input sources to be checked for level or phase inconsistencies. The 5.1 to stereo downmix function is used to create a stereo signal from the selected surround (5.1) source. The stereo to mono downmix function allows audio on the left and right channels to be added (summed) and monitored on the center output channel. The two downmix functions can be simultaneously enabled, allowing a surround source to be checked for mono compatibility. The downmix functions always impact the post-fader surround digital and analog monitor outputs. A configuration setting allows the pre-fader

surround digital monitor output to be selected for pre- or post-downmix operation.

In addition to the surround digital and analog monitor outputs, auxiliary stereo digital and analog monitor outputs are also provided. A stereo signal, connected to stereo input C on the Model 76DBA Central Controller, can be routed to the auxiliary stereo digital and analog monitor outputs. A pushbutton on the Model 77B Control Console allows on/off control of the signal; no level control or signal modification takes place. The auxiliary stereo digital and analog monitor outputs can be useful in special applications, e.g., in a broadcast control room setting where an audio signal, such as site-event cue signals, needs to be monitored by way of an independent set of loudspeakers.

For flexibility, the StudioComm for Surround system is designed to easily integrate with equipment such as production intercom systems, on-air or recording tally signals, and audio consoles. Three remote-control inputs provide access to the mute all, dim, and auxiliary stereo monitor output on/off functions. By providing access to these functions, talkback or slate activity from an audio console or other communications system can control the level of the post-fader surround digital and analog monitor outputs or enable the auxiliary stereo digital and analog monitor outputs.

Installation

In this section you will be installing the Model 76DBA Central Controller in an equipment rack. Connections to the digital audio inputs and digital and analog monitor outputs will be made. A dedicated digital

audio timing reference signal can be connected to the sync input. If desired, a source of Dolby E metadata will be connected and external equipment will be interfaced to the remote control inputs. A location will be selected for the first Model 77B Control Console and it will be connected to the Model 76DBA. AC mains power will be connected to the Model 76DBA. For advanced applications up to three additional Model 77B or Model 71 Control Console units can be connected to the Model 76DBA.

System Components

The main shipping carton contains one each of the following: Model 76DBA Central Controller, Model 77B Control Console, 9-pin D-sub interconnecting cable, and user guide. Also included in the shipping carton is a North American-standard AC mains cord. Your dealer or distributor should provide an AC mains cord appropriate for destinations outside of North America. Any additional Model 77B or Model 71 Control Consoles will be shipped in separate cartons.

Mounting the Model 76DBA

The Model 76DBA Central Controller requires one space (1U) in a standard 19-inch (48.3 cm) equipment rack. Secure the Model 76DBA into the equipment rack using two mounting screws per side. Select a location that is convenient for making connections to the audio signals as well as interfacing with the first (or only) Model 77B Control Console. A cable is supplied to connect the Model 76DBA to the Model 77B. If the needs of a specific installation dictate, an alternate-length interconnecting cable can be fabricated and used.

Audio Connections

Audio connections are made by way of nine BNC jacks and two 25-pin D-subminiature connectors. All the connectors are located on the Model 76DBA's back panel. Refer to Figure 2 for a detailed view of these jacks and the connector.

Digital Audio Inputs

Two surround (5.1) and three stereo digital audio sources can be connected. All sources can be monitored using the pre- and post-fader surround digital and analog monitor output channels. A one-to-one relationship is maintained between the input and output channels, i.e., left input to left monitor output, right input to right monitor output, center input to center monitor output, etc. (Of course this won't be true in the case where the user has enabled one or both of the downmix functions.) Stereo input C is also routed to the stereo input C direct digital and analog monitor outputs.

The digital audio inputs support digital audio signals with a sampling rate of up to 192 kHz and a word length (depth) of up to 24 bits. It's best if the connected signal sources maintain a common sample rate and timing reference. Having all signals "locked" together helps to ensure proper handling by the Model 76DBA's all-digital signal control path.

There is, however, an exception worth noting. Circuitry associated with stereo input C has sample rate conversion (SRC) capability, allowing virtually any digital audio signal to be connected. A signal connected to stereo input C can have an independent sample rate and timing reference and still be monitored correctly. Refer to the Technical Notes section of this guide for a detailed review of the SRC capability.

Stereo inputs A and B can be configured to be used as a stereo source or as two independent monaural sources. When configured as a stereo source the left channel is routed to the left monitor outputs and the right channel to the right monitor outputs. Alternately, the left and right input channels can be independently configured to output by way of the center channel of the surround monitor outputs. In this way a single 2-channel digital audio source can supply one or two monaural signals to the StudioComm system and be correctly monitored.

Stereo input C can serve as a source for the pre- and post-fader surround digital and analog monitor outputs. As with the other inputs, stereo input C can be assigned, using the configuration function, to an input select button. This will allow stereo input C to be monitored using the left and right channels of the surround digital and analog monitor outputs.

In addition, the signal connected to stereo input C will be routed to the auxiliary stereo digital and analog monitor outputs whenever that function is active. To clarify: if the auxiliary stereo digital and analog monitor outputs are enabled a signal on the left channel of stereo input C will be present on the left channel of the auxiliary stereo monitor outputs; a signal on the right channel of stereo input C will be present on the auxiliary stereo monitor outputs' right channel.

Stereo input C is also routed to the stereo input C direct digital monitor output. A one-to-one channel mapping scheme is maintained. The signal present on the stereo input C direct digital monitor output is post (after) the sample rate conversion (SRC) and input delay functions but pre (before) the downmix, level control, and on/off functions.

It's important to note that there is one limitation regarding stereo input C. Unlike stereo inputs A and B, it can only be used as a stereo source. Its left and right channels can't be independently monitored over the center channel of the surround monitor outputs. (The configuration function doesn't allow this anyway so there is no potential for a problem to develop.) Also, the left and right channels of stereo input C can't be independently monitored by way of the auxiliary stereo digital and analog monitor outputs. It follows a left-in-to-left-out, right-in-to-right-out scheme.

Nine BNC jacks on the Model 76DBA's back panel are used to interface with the 18 channels associated with the digital audio signal sources; each BNC connector carries two audio channels. The digital audio inputs are intended for connection with unbalanced digital audio sources that are compatible with the AES3id standard. In broadcast or post-production environments these signals may also be referred to as following the SMPTE 276M standard. This signal type has a nominal impedance of 75 ohms with a nominal signal level of 1 Vpp. As expected, these digital audio sources should be provided in the form of coaxial cables with BNC plugs attached.

Balanced AES3 digital audio signals can also be used with the Model 76DBA's inputs if external coupling transformers ("baluns") are utilized. These impedance-matching (110 ohms to 75 ohms) and level-attenuating transformer assemblies typically provide a 3-pin female XLR connector on their input and a female BNC connector on their output.

Digital Monitor Outputs

The 25-pin D-subminiature connector labeled Digital Monitor Outputs provides access to the Model 76DBA's 16 channels of digital audio monitor output: pre-fader surround, post-fader surround, auxiliary stereo, and stereo input C direct. The pre-fader surround digital monitor output channels are intended for connection to metering or monitoring equipment that requires uninterrupted full-level signals. The post-fader surround digital monitor output channels are intended to connect to a 5.1 loudspeaker system.

The auxiliary stereo digital monitor output is provided to support a separate set of stereo monitor loudspeakers, the primary application intended to allow monitoring of inter- or intra-facility communications.

The stereo input C direct digital monitor output is essentially a unity gain copy of the signal connected to stereo input C. However, the signal does pass through the sample rate conversion (SRC) and input delay circuitry. The impact made by these functions will depend on the specific input signal and the Model 76DBA's configuration settings.

For flexibility the digital monitor outputs are transformer-coupled and can be configured to act as AES3 or AES3id digital audio sources. The digital monitor outputs are configured in two groups with separate choices available for the pre-fader surround/ stereo input C direct group and post-fader surround/auxiliary stereo group. When a group is set for AES3 (110 ohms/5 Vpp) the signals are compatible with AES3 interfaces. Signals of this type are normally interconnected using shielded twisted-pair cable terminated with 3-pin XLR connectors. When a group is configured for AES3id (75 ohms/1 Vpp) the source impedance and

signal level are compatible with the requirements of AES3id interfacing. These signals are typically interconnected using coaxial cable terminated with BNC connectors. For details on how a Model 77B Control Console is used to select the digital monitor output types refer to the Configuration section of this user guide.

A cable assembly with a 25-pin D-sub plug (male) on one end and the desired connectors on the other end will be used for connecting to the digital monitor outputs. The D-subminiature connector follows the TASCAM® wiring convention, organizing the 25 pins into eight groups of three pins each; one pin remains unused. Each set of three pins provides an independent interface. In the analog world this would allow eight audio signals to be transported. But with AES3/AES3id digital audio signals this allows support for 16 audio channels; eight interfaces each supplying two audio channels.

A wiring assembly prepared for the Model 76DBA's digital monitor outputs, when configured for AES3 (110 ohms/5 Vpp), would be identical to that of a DA-88-style output assembly. An assembly of this type would have a male 25-pin D-subminiature connector (DB-25M) on one end and eight 3-pin male XLR connectors on the other. A wiring assembly prepared for the Model 76DBA's digital monitor outputs, when set for AES3id (75 ohms/1 Vpp), would typically have eight BNC plugs attached.

For compatibility with AES3 balanced digital audio signals connect the D-sub's + terminal as signal high and the – terminal as signal low. In most applications a 3-pin XLR plug (male) will be used. In this case the + terminal would go to pin 2 of the XLR, the – terminal to XLR pin 3, and the shield terminal to XLR pin 1.

For compatibility with AES3id unbalanced digital audio signals connect the D-sub's + terminal as signal high, and both the – and shield terminals as the signal low/shield. When terminating to a BNC plug the D-sub's + terminal should connect to the center pin; the – and the shield connections should go to the "body" of the BNC plug. To clarify, for optimal operation it is best to connect both the – and shield connections together directly on the D-sub plug, rather than at the BNC end of the interface assembly. Note that the output circuitry is transformer-coupled so it is possible to just connect to the + and – terminals and still experience correct operation. This would leave the shield connection unterminated.

Refer to Figure 4 or Appendix A for the exact connection details. Note that unlike a DA-88-style assembly, the two threaded fasteners associated with the Model 76DBA's D-sub connectors use 4-40 threads. This complies with the original

Connections	TASCAM® Channel	Signal High (+)	Signal Low (–)	Shield
Pre-Fader L/R	1	24	12	25
Pre-Fader C/LFE	2	10	23	11
Pre-Fader LS/RS	3	21	9	22
Stereo Input C Direct	4	7	20	8
Post-Fader L/R	5	18	6	19
Post-Fader C/LFE	6	4	17	5
Post-Fader LS/RS	7	15	3	16
Auxiliary Stereo	8	1	14	2

- Notes:**
- 1) All signals transformer-coupled digital audio; selectable for AES3 or AES3id compatibility.
 - 2) Connector type on Model 76DBA is 25-pin D-subminiature female (DB-25F). Installer must provide male (DB-25M). Connector uses 4-40 threaded inserts for locking with mating plug.
 - 3) Wiring scheme follows TASCAM DA-88 convention. Standard DA-88-type wiring harnesses are directly compatible, with the possible exception of 4-40 screw threads being required.

Figure 4. Connections for Digital Monitor Outputs

design standard for D-subminiature connectors.

Pre-Fader Surround Digital Monitor Output

The pre-fader surround digital monitor output channels are intended to connect to metering, measurement, or other signal monitoring equipment that requires uninterrupted, full-level digital audio signal sources.

Stereo Input C Direct Digital Monitor Output

The stereo input C direct digital monitor output is intended for use in site-specific applications. It provides an uninterrupted, full-level digital audio signal source that is post-SRC and input delay in the signal chain.

Post-Fader Surround Digital Monitor Output

The post-fader surround digital monitor output channels are designed for connection to digital inputs on audio amplifiers associated with monitor loudspeakers. Alternately, they could be connected to the inputs of loudspeakers that contain integrated amplifiers with digital audio input capability.

Auxiliary Stereo Digital Monitor Output

The auxiliary stereo digital monitor output channels are intended to support a stereo loudspeaker system, either by connecting to the digital input of an amplifier associated with a set of loudspeakers or directly to a set of amplified speakers that provide digital inputs. In either case a user level control must be provided. The StudioComm system is not, by design, able to control the level of the auxiliary stereo digital monitor output.

Analog Monitor Outputs

The connector labeled Analog Monitor Outputs provides access to the Model 76DBA's 6-channel (5.1) post-fader surround and 2-channel auxiliary stereo monitor outputs. The post-fader surround analog monitor output channels are intended to connect to analog inputs associated with the surround loudspeaker system incorporated in a facility. The auxiliary stereo analog monitor output allows support for a secondary set of stereo monitor loudspeakers. The StudioComm system is not, by design, able to control the level of the auxiliary stereo analog monitor output. As such, the loudspeaker system must contain a means of adjusting its output level.

The analog monitor output channels are designed for connection to audio amplifiers associated with monitor loudspeakers or to the inputs of loudspeakers that contain integrated amplifiers. The analog monitor outputs are electronically balanced and will perform optimally when driving loads of 2000 (2 k) ohms or greater. In most applications 3-pin XLR plugs (male) will be used to interface with the inputs on the associated amplifiers or amplified speakers. In this case the + terminal would go to pin 2 of the XLR, the – terminal to XLR pin 3, and the shield terminal to XLR pin 1.

Balanced operation of the analog monitor outputs is the preferred connection method but unbalanced operation does not pose a problem. To connect to an unbalanced load connect the + terminal as signal high, and only the Model 76DBA's shield terminal as the signal low/shield. Leave the – terminal unconnected. For correct unbalanced operation, it is important not to connect – and shield together.

The wiring scheme used by the D-subminiature connector complies with that made popular by TASCAM® with their DA-88® product. A wiring assembly prepared for the Model 76DBA's analog monitor outputs is identical to that of a DA-88-style output assembly. Please refer to Figure 5 or Appendix A for the exact connection details. Again note that unlike a DA-88-style assembly, the Model 76DBA's D-sub connectors use 4-40 threads.

Connections	Signal High (+)	Signal Low (-)	Shield
Surround L	24	12	25
Surround R	10	23	11
Surround C	21	9	22
Surround LFE	7	20	8
Surround LS	18	6	19
Surround RS	4	17	5
Auxiliary Stereo L	15	3	16
Auxiliary Stereo R	1	14	2

Notes: 1) Connector type on Model 76DBA is 25-pin D-subminiature female (DB-25F). Installer must provide male (DB-25M). Connector uses 4-40 threaded inserts for locking with mating plug.

2) Wiring scheme follows TASCAM DA-88 convention. Standard DA-88-type wiring harnesses are directly compatible, with the exception of 4-40 screw threads being required.

Figure 5. Connections for Analog Monitor Outputs

Sync Input

The Model 76DBA requires a timing reference (sync) signal so that the digital audio input and digital monitor output signals will be handled correctly. A configuration setting allows the source of sync to be the L/R input of the currently selected surround or stereo digital audio input. While this is acceptable, audio artifacts (clicks or noise) can occur when switching between inputs. A better method is to connect a

dedicated timing reference signal to the Model 76DBA's sync input connector. The connected sync signal must maintain a stable relationship between itself and the digital audio inputs. The actual sync source can be in one of several formats: word clock, DARS (AES11), bi-level video, or tri-level video.

An overview of the various compatible timing reference signals might prove worthwhile. Word clock is a digital signal that is locked in phase and frequency to the sample rate of the associated digital audio sources. DARS (digital audio reference source) is a timing signal compliant with the AES11 standard. It's sometimes referred to as "AES3-black." Technically it is similar to an AES3 or AES3id signal but is generated specifically as a timing reference signal. Bi-level video sync signals were originally provided to support NTSC and PAL broadcast applications, although they continue to be used by contemporary equipment. Tri-level sync signals were primarily associated with facilities that supported high-definition (HD) video equipment however the importance of this type of sync seems to be waning. Both bi-level and tri-level signals can be found at numerous rate combinations, configured to allow for compatibility with the various video formats.

With the wide range of allowable sync sources proper Model 76DBA operation should be easy to obtain. Extensive testing has been done using many different sync source types and rates. Interested users can refer to Appendix B of this user guide for details.

The external sync reference source is connected to the sync input BNC connector located on the Model 76DBA's back panel.

For flexibility this input can be configured to be high-impedance (“floating”) or terminated with an impedance of 75 ohms. A sync source that is dedicated for use by the Model 76DBA’s sync input will typically have input termination enabled. If the sync signal connected to the Model 76DBA is being connected (“malted”) to other inputs it may be desirable for the termination to be disabled. A general “rule of thumb” is that termination should be applied only at the location of the last physical device using a sync signal.

Metadata Input

The Model 76DBA allows a source of Dolby E metadata to be directly connected. Hardware and software inside the Model 76DBA extracts (“parses”) one of the dialnorm data elements from the connected metadata signal. This dialnorm value can be viewed on the Model 77B’s LED display and, if desired, used to control the level of the post-fader surround digital and analog monitor output channels. Refer to the Technical Notes section of this guide for details.

The metadata signal is connected by way of a 9-pin D-subminiature connector, labeled RS-485/Remote Control Inputs, which is located on the back panel of the Model 76DBA. Refer to Figure 6 or Appendix A for exact connection details. While only the data + and data – connections are absolutely necessary, a shield connection can also be made. Note that the connections for the metadata signal are reminiscent of the SMPTE 207M standard.

The metadata signal must be in the form of RS-485 or RS-422 asynchronous serial data. This differential signal must have a data rate of 115.2 Kbit/s and a data format of 8 data bits, no parity, and 1 stop bit

(8-N-1). A metadata signal of this type is commonly available on metadata-generating or de-embedding equipment from broadcast equipment manufacturers such as Dolby Laboratories®, Evertz®, and Miranda®.

While in hardware the Model 76DBA’s RS-485 input connection is bi-directional, in software it’s configured only to receive data. The input impedance is 2200 ohms, almost 20 times the nominal value for RS-485. This means that there’s no reason why a signal already connected between two other pieces of equipment can’t also be connected in parallel (“bridged”) with the Model 76DBA’s metadata input.

A word of advice—Studio Technologies has found documentation supplied with some metadata-generating equipment has incorrect (or at least confusing) pin-out information. This has resulted in much head scratching and hair pulling. As such, it may be valuable to use a logic analyzer or oscilloscope to confirm that the metadata source is on the expected pins of the source connector prior to connecting it to the Model 76DBA.

Signal	Pin	Direction
Data + (RS-485/RS-422)	7	Input
Data – (RS-485/RS-422)	2	Input
Data Shield	1	Shield
Remote Mute All	5	Input
Remote Dim	6	Input
Remote Aux Stereo Monitor Out On/Off	8	Input
Remote Spare	9	Input
Remote Common	4	Common

Note: Connector type on Model 76DBA is 9-pin D-subminiature female (DE-9F) Connector uses 4-40 threaded inserts for locking with mating plug.

Figure 6. Connections for Metadata and Remote Control Inputs

Remote Control Inputs

Support is provided for three remote control input functions: remote mute all, remote dim, and remote auxiliary stereo monitor output on/off. Note that the remote mute all and remote dim functions only impact the post-fader surround digital and analog monitor outputs.

The Model 76DBA's inputs use logic gates, "pulled up" to +5 volts DC by way of resistors, which are active whenever they are brought to their logic low state. Inputs of this type are commonly referred to as GPI inputs. While the input circuitry is protected from over-current and static (ESD) discharge, care should be taken to prevent nasty signals from reaching them. The inputs are active only when held in the low state; they can't be configured to change state ("latch") in response to a logic pulse.

The same 9-pin D-subminiature connector used for the metadata input is also used for the remote control inputs. Refer to Figure 6 or Appendix A for the exact connection details. Note that pin 4 (remote common) connects to the Model 76DBA's internal circuit common connection as well as to the Model 76DBA's chassis and mains earth connections. Figure 6 also shows one spare remote control input (pin 9). This is provided for future applications and should remain unconnected.

Connecting the Model 76DBA to the Model 77B

A 9-pin female D-subminiature connector, labeled To/From Control Consoles, is provided on the back panel of the Model 76DBA Central Controller. This is used to interface the unit with Model 77B Control Consoles. Refer to Figure 7 or Appendix A for details. A 9-pin female D-sub connector,

Signal	Pin	Direction
Data + (RS-485)	1	To/From Models 77B/71
Data - (RS-485)	6	To/From Models 77B/71
Data Shield	2	To/From Models 77B/71
DC + (12 V)	4	To Models 77B/71
DC - (12 V Return)	9	To Models 77B/71
DC Power Shield	5	To/From Models 77B/71

Note: Connector type on Model 76DBA is 9-pin D-subminiature female (DE-9F). Connector uses 4-40 threaded inserts for locking with mating plug.

Figure 7. Connections between Model 76DBA and Model 77B and Model 71

labeled To/From Central Controller, is provided on the back panel of each Model 77B Control Console. A cable with 9-pin male D-sub (DE-9M) connectors on each end is used to interconnect the Model 76DBA with the Model 77B units. A cable is included in the shipping carton. The cable implements all nine connector pins in a one-to-one manner.

Should an interconnecting cable of a different length be required there's no problem for one to be fabricated and used. While it can be wired in a one-to-one fashion supporting all nine pins, only four connections are required: pin 1 (data +), pin 6 (data -), pin 4 (DC +), and pin 9 (DC -). The Model 76DBA's connector pin-out scheme was designed to allow creation of an interconnecting cable which uses commonly available 2-pair audio cable. This cable, consisting of two twisted pairs each with an individual shield, is typically sleek, flexible, and available in many colors. One pair and shield can be used for the data connections while the other pair and shield can be used for the DC connections. This implementation has the advantages of providing a shield for the data path and a more robust common connection (two conductors including the shield) for the DC power circuit.

A few simple calculations are required to determine the maximum cable length when connecting a Model 76DBA to a Model 77B. The differential transmission scheme used by the system's RS-485 interface makes an interconnection in excess of 1000 feet (>300 meters) easily possible. The limiting factor is typically the ability of the wiring to pass the DC power supplied by the Model 76DBA to a Model 77B. The Model 76DBA supplies 12 volt DC with a maximum current of 500 milliamperes.

The Model 77B requires a minimum of 9 volts DC, 100 milliamperes, for correct operation. (The voltage must be measured directly at the Model 77B's 9-pin connector.) So the maximum interconnecting cable length is directly related to the resistive voltage losses associated with the two DC-carrying conductors. As the Model 76DBA supplies 12 volts and the Model 77B requires 9 volts minimum, this directly leads to a 3 volt DC maximum drop due to the interconnecting cable. Using Ohm's law it's quite easy to determine whether the selected cable will support the desired interconnection length. Calculate the voltage drop by multiplying the total resistance (in ohms) of the proposed cable by 0.1 (the Model 77B's required current in amperes). Remember to include the resistance in both the DC + and DC – wires when calculating the voltage drop. If it's greater than 3 volts your cable is too long or the wire gauge is too small.

Additional Control Consoles

Some installations may benefit from the Model 76DBA's ability to be controlled by additional control consoles. At least one Model 77B Control Console must be connected to the Model 76DBA Central Controller. After this requirement has been met

up to three additional Model 77B or Model 71 Control Consoles can also be connected and powered by the Model 76DBA.

When connecting multiple control consoles to a Model 76DBA all nine pins of each interconnecting cable can be connected in parallel (multed). Using this arrangement the data and 12 volt DC power signals between all the units will be multed. A custom cable implementation requires just four pins to be connected: pin 1 (data +), pin 6 (data –), pin 4 (DC +), and pin 9 (DC –).

To make installation simple, a "bus" cable assembly can be created using a short length of ribbon cable with one male and multiple female 9-pin D-subminiature insulation-displacement connectors attached. Then standard 9-pin cables can link the control consoles with the connectors on the bus cable.

Refer to the previous paragraphs of this user guide where the issues involving Model 76DBA to Model 77B cable length are discussed. Note the required current for a Model 77B is 100 milliamperes while a Model 71 requires only 35 milliamperes. It's important to review this information prior to creating the interconnection scheme to be used for installing multiple Model 77B units.

AC Mains Power

The Model 76DBA operates directly from AC mains power of 100 to 230 V, 50/60 Hz. Being a "universal input" device, there are no switches to set or jumpers to install to match a location's mains voltage. The unit uses a 3-pin IEC 320 C14-type inlet connector to mate with a detachable mains cord. All units are supplied with a mains cord that has a North-American standard plug (NEMA 5-15L) on one end and an

IEC 320 C13 socket on the other. Units bound for other destinations require that the appropriate cord be used. The wire colors in the mains cord must conform to the internationally recognized color code and should be terminated accordingly:

<u>Connection</u>	<u>Wire Color</u>
Neutral (N)	Light Blue
Line (L)	Brown
Protective Earth (E)	Green/Yellow

Safety Warning: The Model 76DBA does not contain an AC mains disconnect switch; the AC mains cord plug serves as the disconnection device. Safety considerations require that the plug and associated outlet be easily accessible to allow rapid disconnection of AC mains power should it prove necessary.

As soon as mains power is applied the Model 76DBA will perform a power-up sequence. The three LEDs on the right side of the front panel will individually light in a rapid right-to-left test sequence. Then the LEDs will flash in cadence while the firmware loads into the Model 76DBA's main logic device. After just a few seconds initial system operation will commence and the three LEDs will perform their intended functions. Once operating data is being interchanged with the one or more connected Model 77B or Model 71 Control Consoles the control console status LED will also light. If a source of metadata has been connected and valid data is present the metadata status LED will light. The sync status LED will light if a valid sync source has been recognized. The sync status LED will flash if a valid sync source is not recognized.

Also upon application of mains power, all connected Model 77B units will go through a power-up sequence, lighting each of its LEDs in succession. Using its 4-digit display, each Model 77B will then momentarily display its address, its software version, and the main and logic device software versions of the associated Model 76DBA.

All connected Model 71 units will also go through a power-up sequence after mains power is applied to the Model 76DBA. Each of the Model 71's three LEDs will light momentarily. After these LEDs have been lit, the device address will be shown briefly using the dim and reference level LEDs, as shown in Figure 8 in the Operation section. When this is complete the Model 71 will begin normal operation and its status LED will light if communication is established with the Model 76DBA. If the Model 71's status LED does not light check to see if there is a device address conflict among all connected control consoles and that all cables are connected properly.

Should an error be detected during the start-up process the two LEDs on the Model 76DBA's front panel will continue to flash in cadence indefinitely. On the Model 77B units a diagnostic code may be displayed. Refer to the Technical Notes section of this user guide for details.

Only after the Model 76DBA and all connected Model 77B and Model 71 units have correctly powered up will full system operation begin. It's possible that audio signals will first be present on the digital monitor outputs. The analog monitor outputs will only become active after a protection interval has elapsed. These outputs are muted using electro-mechanical relays that operate under software control.

Configuration

After the physical installation has been completed it's important that the system's configuration options be carefully reviewed. In most cases one or more of the operating parameters will need to be revised to meet the needs of the specific installation. Many of the configuration parameters will impact the signal flow in to and out of the Model 76DBA Central Controller. Other parameters affect how the one or more Model 77B Control Consoles will display status conditions and respond to user commands. Most of the configuration choices will be made using a Model 77B Control Console. However, one configuration choice is available for each of the connected Model 71 Control Consoles.

Configurable Parameters

Many StudioComm functions can be configured to meet the exact needs of an installation. A Model 77B Control Console is used to display and select the desired system configuration. Here's an overview of what can be configured:

- Model 77B Device Address (unique for each unit)
- Stereo Input C Sample Rate Converter
- Auxiliary Monitor Output Nominal Level
- Sync Source
- Sync Input Termination
- Audio-Synced-to-Video Sample Rate
- Digital Monitor Output Types
- Input Select Buttons
- Reference Level
- Overall Display Mode
- Reference Level in dB SPL

- Auto Reference Level Off
- Dialnorm Reference Level
- Dialnorm-Data-to-Surround-Input Assignment
- Dim Level
- Remote Inputs
- Input Delay
- LFE Downmix Mode
- Pre-Fader Surround Digital Monitor Output Mode
- Channel Pop Solo Mode Offset Levels

The configuration diagrams, located later in this section, give details on setting each parameter. An overview of each configurable parameter is provided in the following paragraphs.

Entering and Exiting the Configuration Mode

A small button is located on the back of each Model 77B Control Console, adjacent to its 9-pin D-sub connector. On any connected Model 77B pressing and holding this button for two seconds places both this specific unit and the Model 76DBA into their configuration modes. Other connected Model 77B and Model 71 units will enter a standby mode. When the Model 76DBA enters its configuration mode it will immediately mute the digital and analog monitor outputs as a speaker protection measure. When a Model 77B enters the configuration mode its array of buttons and LEDs no longer perform their normal functions, instead they are used to display the operating parameters and reflect configuration changes as they are made.

As a user aid, a Model 77B that has entered the configuration mode will have its

dialnorm and output level LEDs (associated with the display mode section) light in an alternating manner. Other connected Model 77B units will indicate that they have entered the standby mode by simultaneously flashing their dialnorm and output level LEDs.

To leave the configuration mode and return the system to normal operation requires one last action to be made on the Model 77B unit that's in its configuration mode; press and hold its configure the button for two seconds. Note that configuration changes are stored in nonvolatile memory only after the configuration mode has been exited.

Our apologies to those of you who find the configure button a pain to use, but it's supposed to be that way! Seriously, the top of the button is slightly recessed from the back panel, making it harder to accidentally activate. We didn't want normal operation to cease because someone pushed a Model 77B into a "rats nest" of schedules, memos from management, and empty coffee cups! But a firm press with the fleshy part of an index finger should do the trick.

There is no problem frequently "tweaking" the system's operating parameters to achieve the desired performance. The configuration data is stored in nonvolatile memory, which is rated for thousands of read and write cycles and a retention time in tens of years. Note that memory integrated circuits are located in the Model 76DBA Central Controller as well as the Model 77B and Model 71 Control Consoles. However, only the individual device address is stored in each Model 77B and Model 71. All other configuration parameters are stored in the Model 76DBA.

Model 77B Device Address

A unique device address must be assigned to each Model 77B that is connected to a Model 76DBA. The choices are A1, A2, A3, or A4, with the default address being A1. As most installations will find only one Model 77B utilized, its default setting is appropriate. For installations that use a second, third, or fourth Model 77B each unit must be configured with a unique device address. Problems will occur if more than one unit has the same address! It's important to highlight the fact that the device address is the only setting that must be done on each individual Model 77B unit. All other settings can be made on any one of the connected Model 77B units. Be sure that any selected address does not conflict with addresses to be assigned to Model 71 units.

Stereo Input C Sample Rate Converter

Circuitry associated with stereo input C can provide sample rate conversion (SRC) for digital audio signals connected to that input. The acceptable input range for sample rate conversion is very wide, but is dependent upon the output sample rate. With an output sample rate of 48 kHz any signal with a sample rate over a range of 8 to 216 kHz can be properly monitored by the system. This capability can be especially useful with signals that are not synchronized with respect to the others connected to the Model 76DBA, even if the sample rate is identical. The only compromise is that the SRC process adds a fixed input-to-output (group) delay of approximately 1 millisecond, a value that shouldn't impact most installations. As such, it's recommended that the sample rate converter

remain enabled. However there might be special cases where this resource isn't desired and it can be disabled.

Auxiliary Stereo Monitor Output Nominal Level

The nominal level of the auxiliary stereo digital and analog monitor outputs can be configured to match the requirements of a specific installation. Devices connected to the auxiliary stereo digital and analog monitor outputs could include an amplifier associated with a loudspeaker system or inputs on self-contained amplified loudspeakers. (These types of devices must include a means of adjusting their output level.) This configuration setting defines the relative output level when an input source is connected and the auxiliary stereo digital and analog monitor outputs are enabled. The choices are 0, -6, -12, or -18 dB. The 0 dB setting will typically be correct when connecting to the input of a device that's not associated with a loudspeaker system. With no gain or loss, this setting creates a unity-gain input-to-output relationship. Devices such as amplified speakers will often perform better when receiving signals with a lower nominal level. In this case the ability to comfortably use a level potentiometer may be enhanced by selecting the -6, -12, or -18 dB settings.

Sync Source

The Model 76DBA requires that the designated external timing reference (sync) be defined. Three of the choices—word clock, DARS, and video—are associated with a signal that is connected to the sync input BNC connector. The fourth choice allows the L/R input of the currently selected surround or stereo digital audio input to serve as the system's sync source.

Sync Input Termination

The sync input circuitry can be configured to terminate the signal connected to the back-panel sync input BNC connector. When termination is selected a 75 ohm load is applied to the signal. When the sync input is not terminated the input impedance is very high, essentially applying no load to the source. If the sync source is connected only to the Model 76DBA then enabling termination is typically appropriate. However, if the sync source is being "shared" by multiple inputs then care must be taken so that the signal is only terminated by one device.

Audio-Synced-to-Video Sample Rate

If a video sync signal is being used as the Model 76DBA's timing reference the sample rate of the connected digital audio signals must be specified. In most cases the default value of 48 kHz will be appropriate, but rates from 32 to 192 kHz are available.

Pre-Fader Surround/Stereo Input C Direct Digital Monitor Output Type

To meet the needs of specific installations the nominal impedance and level characteristic of the pre-fader surround and stereo input C direct digital monitor outputs can be selected. They are selected as a group; configuration of individual digital outputs is not provided. If the digital output signals are going to be connected to balanced AES3 inputs then the setting that provides a source impedance of 110 ohms and a nominal 5 Vpp output level would be appropriate. If the digital output signals are going to be connected to unbalanced

AES3id inputs then the setting that provides a 75 ohm source impedance and a nominal output level of 1 Vpp would be correct.

Post-Fader Surround/ Auxiliary Stereo Digital Monitor Output Type

The source impedance and output level of the post-fader surround and auxiliary stereo digital monitor outputs, as a group, can be configured. The information previously provided concerning configuring the pre-fader surround/stereo input C direct digital monitor output type also applies to these outputs.

Input Select Buttons

The three input select buttons, along with the group select button, allow six source configurations to be selected for monitoring. The Model 76DBA has connections for two surround (5.1) and three stereo AES3id digital audio sources. Any of these sources can be assigned to any of the input select buttons. To fit broadcast applications where it's typical for non-stereo pairs to share an AES3id 2-channel path, the individual left and right audio channels of stereo inputs A and B can be assigned to separate input select buttons as required. These "mono" signals will be routed to the center pre- and post-fader surround monitor output channels.

Spending time reviewing the input select button configuration function may prove very worthwhile. It is a unique feature of this StudioComm for Surround system and offers a great opportunity to optimize monitoring performance.

Reference Level

For audio-with-picture applications it's often beneficial for monitoring to be done in reference to a known loudspeaker level. This is often referred to as "mixing to 85 dB" on the monitors. The StudioComm for Surround system allows a precise post-fader surround digital and analog monitor output level to be stored, and then enabled by pressing the Model 77B button labeled Reference Level. Setting the reference level is very simple but care is required:

1. Set up a precision sound pressure level (SPL) measuring device at the desired listening location.
2. Place the StudioComm system in the normal operating mode, not the configuration mode. Be certain that the dim, mute all, reference level, dialnorm enable, and downmix functions are not active. The remote mute all and remote dim functions must also not be active.
3. Use the Model 77B Control Console to select the input source that contains the desired reference signal source, e.g., pink noise.
4. Observing the SPL meter, adjust the Model 77B's rotary level control until the desired loudspeaker system reference level has been reached.
5. Being careful not to disturb the position of the rotary level control, enter the configuration mode by pressing and holding the configuration button located on the Model 77B's back panel.
6. Once the configuration mode has been entered, all the monitor outputs (digital and analog) will mute. Press and hold the reference level button; its associated LED will begin to flash. After five

seconds the LED will light steadily to indicate that a “snapshot” of the new reference level has been taken. The Model 77B’s numeric display will then show the value of the new reference level. The value shown will always be a negative number as it’s always a value less than the maximum output level. The reference level button can now be released.

7. To complete the process the configuration mode must be exited. This is performed by again pressing and holding the configure button for two seconds. The new reference level is now stored in the Model 76DBA’s nonvolatile memory. Only by repeating the entire procedure can the value be changed.

Once the configuration mode has been exited, the digital and analog monitor outputs will again become active. Confirm that the correct level has been stored by pressing the reference level button. The SPL meter should display the desired level. If not, repeat the calibration procedure to achieve the desired goal.

You might wonder why you have to press and hold the reference level button for five seconds before the selected value is recognized. This is provided specifically so that unauthorized users won’t accidentally change the reference level while they experiment with the configuration mode. Only if you know the “secret” will you be able to store a new value.

Overall Display Mode

The Model 77B’s 4-digit numeric display can be configured to display the post-fader surround digital and analog monitor output levels in either an attenuation mode

or an SPL mode. In the attenuation mode the output level is shown as a reduction in level, in dB, relative to the maximum output level. When the rotary control is used to set the output level to its maximum the display will show **0.0**. As the rotary control is moved in the counterclockwise direction the display will show negative values, reaching **-70.0** before the full mute function automatically mutes the outputs.

In the SPL mode the display can be configured to allow the output level to be presented to users in terms of the actual sound pressure level (SPL). Used in conjunction with the reference level in dB SPL configuration and the stored reference level, SPL mode allows a user to see a visual representation of the SPL level that is present in the listening environment. While it takes a little more care to correctly implement the SPL display mode, it can offer an enhanced experience for StudioComm users.

Reference Level in dB SPL

The reference level in dB SPL configuration allows a specific SPL value to be associated with the stored reference level value. In this way whenever the post-fader surround digital and analog monitor outputs are at their reference level, either through activating the reference level function or manually adjusting the rotary level control, the Model 77B’s display will show the configured SPL level. Whenever the monitor output is not at the reference value the display will show the current value, in dB, relative to the reference level. The reference level in dB SPL can be configured over a range of 70.0 to 100.0 dB in 1.0-dB steps. In many applications selecting a value of 85 would be appropriate,

reflecting the widely used audio-for-picture 85 dB monitoring reference level. (Typically this 85 dB is really 85 dBC, indicating that a C-weighting filter has been applied to the measurement.) Other common reference SPL values, such as 82 dB and 87 dB, are well within the allowable range.

Auto Reference Level Off

When auto reference level off is enabled, the function automatically turns the reference level function off if a change is made to the rotary level control while the reference level function is active.

Dialnorm Reference Level

The dialnorm reference level parameter is provided so that the StudioComm system can be configured to match a facilities' or "plant" default dialnorm level. This value is used as a reference against which the post-fader surround digital and analog monitor output levels will, if enabled, be adjusted up or down in response to an incoming dialnorm value. The dialnorm reference level parameter can be adjusted over the entire -31 to -1 dB range but typical values will be in the range of -27 to -24 . Implementation purists might want to select -31 dB as it may well be the "truest" implementation of the dialnorm scheme. In this way the system will, when enabled, reduce the monitor output level whenever dialnorm is different than -31 dB. But as bar fights have broken out over decisions such as this we'll leave the choice up to you! For additional information about dialnorm refer to the Technical Notes section of this user guide.

Dialnorm-Data-to-Surround-Input Assignment

For correct operation the connected Dolby E dialnorm data must be assigned to work in conjunction with its associated surround input. In this way the dialnorm data will only display, and level changes will only take place, when the appropriate surround input is selected by an operator.

Dim Level

The dim function is used to reduce the post-fader surround digital and analog monitor output levels by a preset amount. The reduction is in dB relative to the post-fader surround digital and analog monitor outputs' current level. There are four dim level values available: -10.0 , -15.0 , -20.0 , and -25.0 dB.

Remote Mute All

Two configuration choices are associated with the remote mute all function: disabled and enabled. To utilize the remote mute all function simply requires you to select the enabled setting.

Remote Dim

Two configuration choices are associated with the remote dim function: disabled and enabled. To utilize the remote dim function simply configure it for enabled.

Remote Auxiliary Stereo Monitor Output On/Off

This function configures whether the on/off status of the auxiliary stereo digital and analog monitor outputs can be controlled using the remote control input.

Input Delay

A time delay can be added to the input signals, allowing compensation for delays that may be present on associated video signals. The selected time delay applies to all input signals and cannot be applied selectively. The configured delay time is referenced to a sample rate of 48 kHz. In the case of input signals with a sample rate of 48 kHz the delay range is 0 to 340 milliseconds in 1-millisecond steps. For other sample rates the time must be linearly scaled. For example, for a sample rate of 96 kHz the actual time range is 0 to 170 milliseconds. In this case selecting a delay of 120 on the Model 77B will result in an actual time delay of 60 milliseconds. For 192 kHz sampling the time range is 0 to 85 milliseconds. Selecting a delay of 240 will result in a time delay of 60 milliseconds.

LFE Downmix Mode

By default, when the 5.1 to stereo downmix function is active the LFE channel associated with a surround input is muted. This removes LFE content from the downmixed signal. In most applications this is appropriate. However, for special situations a configuration mode allows the LFE channel to be part of the downmix signal flow. When the LFE downmix mode is enabled, if surround input A or B is the currently selected input and the 5.1 to stereo downmix function is active, the LFE signal level is reduced in level by 6 dB and added to both the left and right output channels. As expected, even when the LFE downmix mode is active the digital and analog LFE output channels will still mute when 5.1 to stereo downmix is active.

Pre-Fader Surround Digital Monitor Output Mode

The pre-fader surround digital monitor output can be configured as to its place in the Model 76DBA's signal flow. The choices are pre- or post-downmix. In the pre-downmix mode the digital monitor output channels will not be impacted by the state of the downmix functions. This setting would be appropriate if the pre-fader digital surround monitor outputs were being routed to a storage system, routed to another facility, etc. In this case the action of an operator enabling or disabling the downmix functions won't impact the pre-fader surround digital monitor output signals. If the post-downmix mode is selected the pre-fader surround digital monitor outputs will reflect the actions of the downmix functions. This choice would be correct if, for example, level meters were connected to the pre-fader surround digital monitor outputs. In this scenario an operator would want to visually observe the actions that the downmix functions impart on the signals.

Channel Pop Solo Mode Offset Levels

Two parameters can be configured that determine how the channel pop solo function impacts audio levels. The up offset level sets the amount of increase (gain) that a channel will experience when it is soloed in the channel pop solo mode. The down offset level sets the amount of decrease (attenuation) that the non-soloed channels will experience when a channel is active in the channel pop solo mode.

Restore Factory Defaults

The restore factory defaults function is provided primarily for factory use. In this way a system can be shipped with the default settings selected. While you are welcome to use this function, be careful so that your configuration efforts aren't wasted. Specifically, be aware that the reference level is reset to minimum level. All the other parameters are fairly easy to set up, but resetting the reference level would require getting out an SPL meter and a calibrated signal source. This is a hassle you may not need!

Model 71 Control Console Configuration

The only configuration choice available on a Model 71 is its device address. It must be selected so as not to conflict with the device address of any other connected Model 71 or Model 77B Control Console. The choices are A1, A2, A3, and A4. All Model 71 units have a default device address of A4; Model 77B's units have a default device address of A1. This ensures that, in most cases, no change will have to be made. Refer to Figures 8 and 9 for details.

A small button is located on the back of each Model 71 Control Console, adjacent to the 9-pin D-sub connector. Pressing and holding this button for two seconds places this specific unit in its configuration mode; normal operation of the Model 76DBA and other connected Model 71 and Model 77B units will continue. When a Model 71 enters its configuration mode its three LEDs will no longer perform their usual functions. Instead the status LED will blink to indicate that configuration mode is active. The dim and reference level LEDs will display

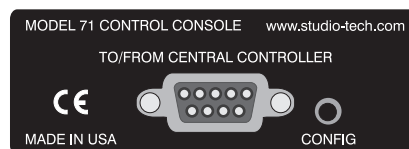
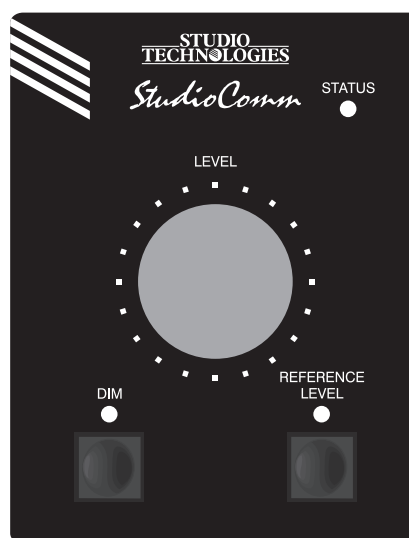

Figure 8. Model 71 Control Console Front and Back Panels

Address	Dim LED	Reference Level LED
A1	OFF	OFF
A2	OFF	ON
A3	ON	OFF
A4	ON	ON

Figure 9. Model 71 Device Address Chart

the Model 71's current device address. The rotary level control is used to select the desired device address; the LEDs will respond accordingly.

To leave the configuration mode and return a Model 71 to normal operation requires one last action; again press and hold its configure button for two seconds. The selected device address will be stored in a nonvolatile memory device that is located inside this specific Model 71.

Configuration—Entering and Exiting Configuration Mode

 Press and hold the configuration button for 2 seconds to enter or exit the configuration mode.

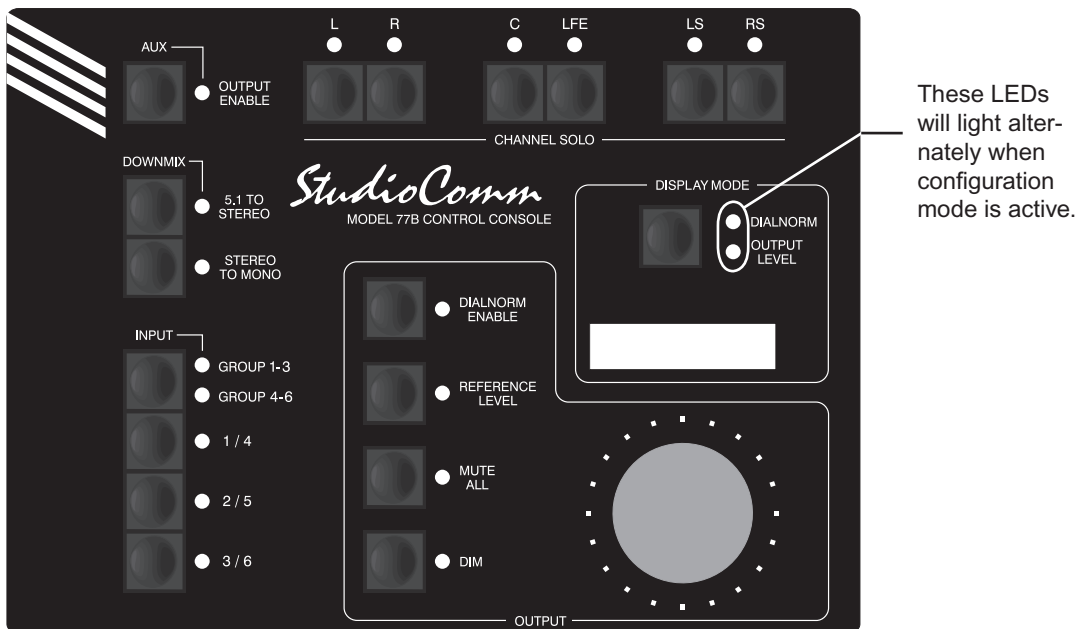
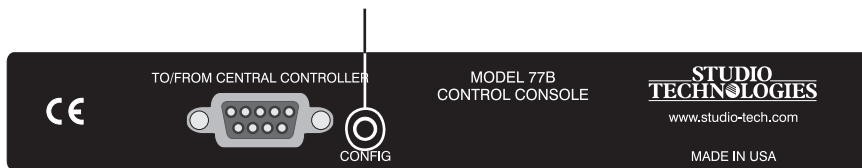

Configuration—Model 77B Device Address, Stereo Input C Sample Rate Converter, and Auxiliary Stereo Digital and Analog Monitor Outputs Nominal Level



Press and hold the Auxiliary Output Enable button to display and select the Model 77B's device address, stereo input C sample rate converter, and auxiliary stereo digital and analog monitor outputs nominal level.

This LED displays the configuration of the **stereo input C sample rate converter (SRC)**. LED not lit means SRC is bypassed; LED lit means SRC enabled. Use the button to change the configuration.

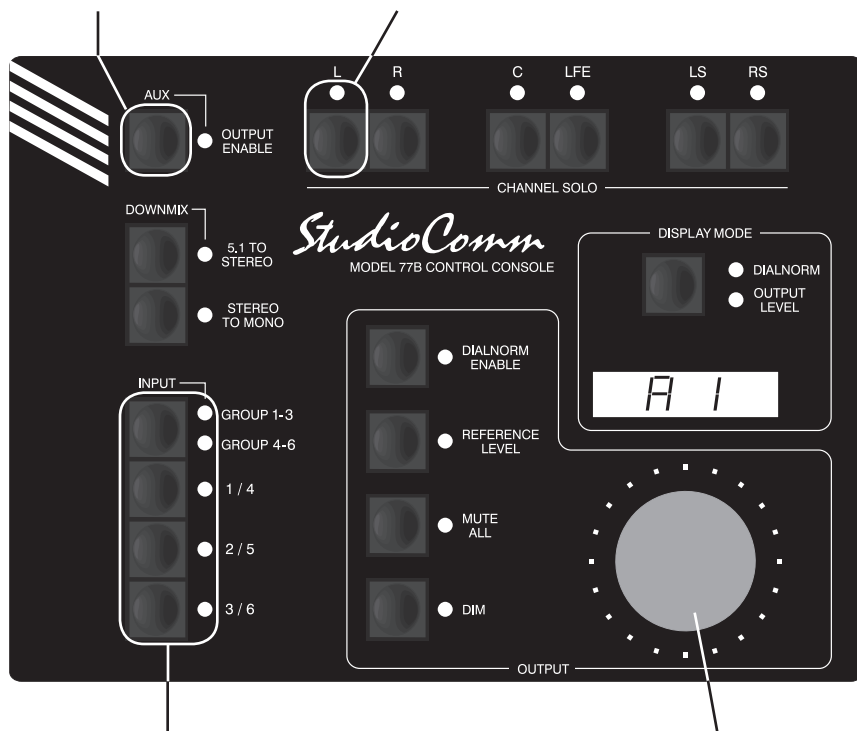

Use the input buttons to select the nominal level of the **auxiliary stereo digital and analog monitor outputs**. LED Group 1-3 lit means the output level is 0 dB; LED 1/4 lit means the output level is -6 dB; LED 2/5 lit means the output level is -12 dB; LED 3/6 lit means the output level is -18 dB.

Use the level control to change this specific Model 77B's **device address**. Address can be either A1, A2, A3, or A4.

Default: Device address A1.
Stereo input C sample rate converter enabled.
0 dB auxiliary stereo digital and analog monitor outputs nominal level.

Note: The Model 77B's device address is the only parameter stored in the Model 77B. All other parameters are stored in the Model 76DBA.

Configuration—Sync Source, Sync Input Termination, Audio-Synced-to-Video Sample Rate, and Digital Monitor Output Types

This LED displays the configuration of the **sync input termination**. LED not lit means sync input is not terminated; LED lit means terminated with 75 ohms. Use the button to change the configuration.

Use the Channel Solo C and LFE buttons to select the **pre-fader surround/stereo input C direct digital monitor output type**. Use the buttons to change the configuration. C LED lit means AES3id (75 ohms/1 Vpp); LFE LED lit means AES (110 ohms/5 Vpp).

Use the Channel Solo LS and RS buttons to select the **post-fader surround/auxiliary stereo digital monitor output type**. Use the buttons to change the configuration. LS LED lit means AES3id (75 ohms/1 Vpp); RS LED lit means AES3 (110 ohms/5 Vpp).

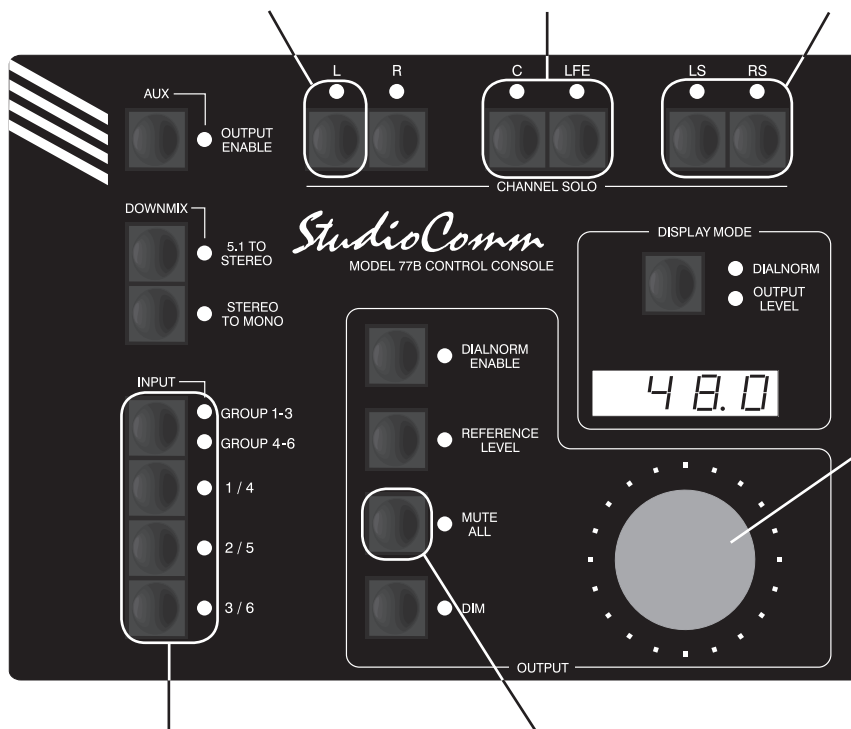

Use these buttons to select **sync source**:
LED Group 1-3 lit means sync input, video
LED 1/4 lit means sync input, DARS
LED 2/5 lit means sync input, word clock
LED 3/6 lit means L/R of currently selected input

 Press and hold the Mute All button to display and select the sync source, sync input termination, audio-synced-to-video sample rate, and digital monitor output types.

Use the level control to adjust the **audio-synced-to-video sample rate**. Available sample rates are 32, 44.1, 48, 88.2, 96, 176.4, and 192 kHz.

Default: Sync source is L/R of currently selected input.
Sync input terminated.
Audio-synced-to-video sample rate 48 kHz.
Pre-fader surround/stereo input C direct digital monitor output type AES3 (110 ohms/5 Vpp).
Post-fader surround/auxiliary stereo digital monitor output type AES3 (110 ohms/5 Vpp).

Configuration—Input Select Buttons

When an input button is pressed use the L and R buttons to assign **stereo input A** to that button. Both L and R LEDs lit means stereo input A is assigned to that button as a stereo source; L LED only lit means channel 1 of stereo input A is routed to the center output and channel 2 is not used; R LED only lit means channel 2 of stereo input A is routed to the center output and channel 1 is not used.

When an input button is pressed use the C and LFE buttons to assign **stereo input B** to that button. Both C and LFE LEDs lit means stereo input B is assigned to that button as a stereo source; C LED only lit means channel 1 of stereo input B is routed to the center output and channel 2 is not used; LFE LED only lit means channel 2 of stereo input B is routed to the center output and channel 1 is not used.

When an input button is pressed use the LS button to assign **stereo input C** to that button. Both LS and RS LEDs lit means stereo input C is assigned to that button as a stereo source. Individual stereo input C channels cannot be routed to center output.

When an input button is pressed use the 5.1 to Stereo button to assign **surround input A** to that button. Use the Stereo to Mono button to assign **surround input B** to that button.

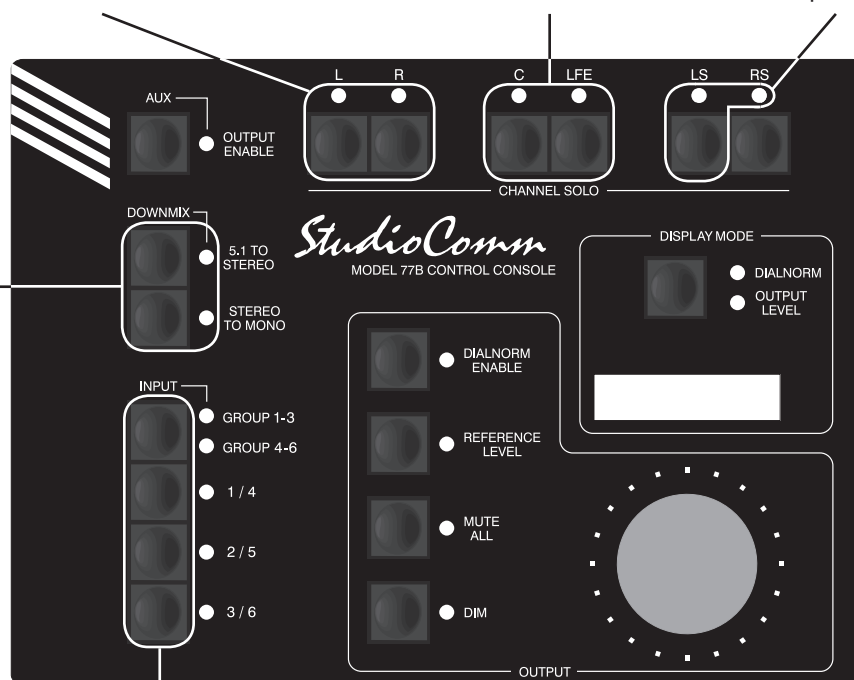

 Press and hold an input button to display and select which input source is assigned to that button in Group 1-3. Press and hold both the group select button and an input button to display and select which input is assigned to that button when Group 4-6 is active.

Default: Surround input A assigned to input 1.
Surround input B assigned to input 2.
No input assigned to input 3 (disabled).
Stereo input A assigned to input 4.
Stereo input B assigned to input 5.
Stereo input C assigned to input 6.

Note: If no input is assigned to an input button that button is disabled.

Configuration—Reference Level

-  Press and hold the Reference Level button for 5 seconds to take a “snapshot” of the level control’s setting at the time configuration mode was entered. The Reference Level LED will flash when the button is initially pressed and then light solid when the “snapshot” has been taken.

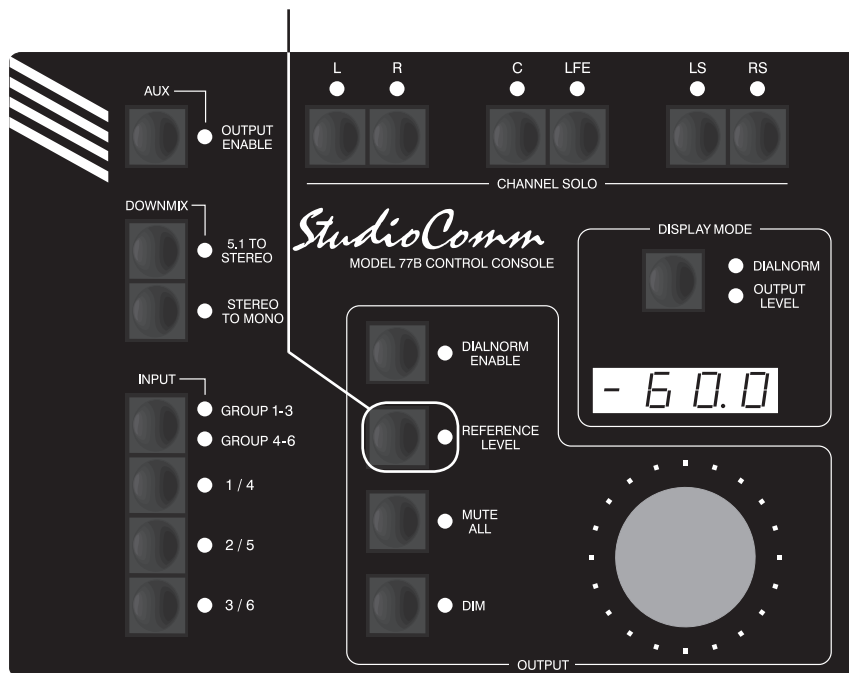

Default: -60.0 dB post-fader surround digital and analog reference output level.

Note: The 5-second delay is a safety feature ensuring that the reference level will not be accidentally changed. To permanently store the new value, you must still exit the configuration mode.

Configuration—Overall Display Mode and Reference Level in dB SPL

Use the Channel Solo L and R buttons to select the **overall display mode**. L LED lit means attenuation mode is selected; R LED lit means SPL mode is selected. Use the buttons to change the configuration.

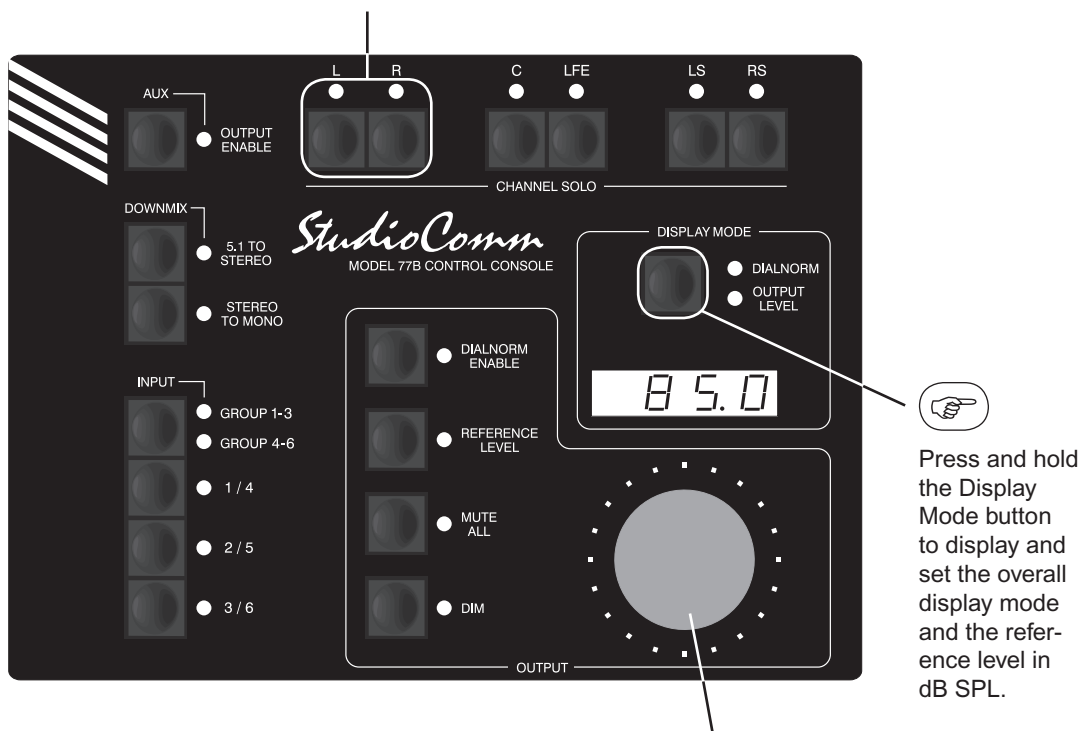

Use the level control to adjust the **reference level in dB SPL**. The range is 70.0 to 100.0 dB in 1.0-dB steps.

Default: Attenuation display mode selected.
85.0 dB SPL reference level.

Configuration—Dialnorm Reference Level and Dialnorm-Data-to-Surround-Input Assignment

Use the Downmix 5.1 to Stereo and Stereo to Mono buttons to **assign the dialnorm data to the appropriate surround input**. LED 5.1 to Stereo lit means dialnorm data assigned to surround input A; LED Stereo to Mono lit means dialnorm data assigned to surround input B.

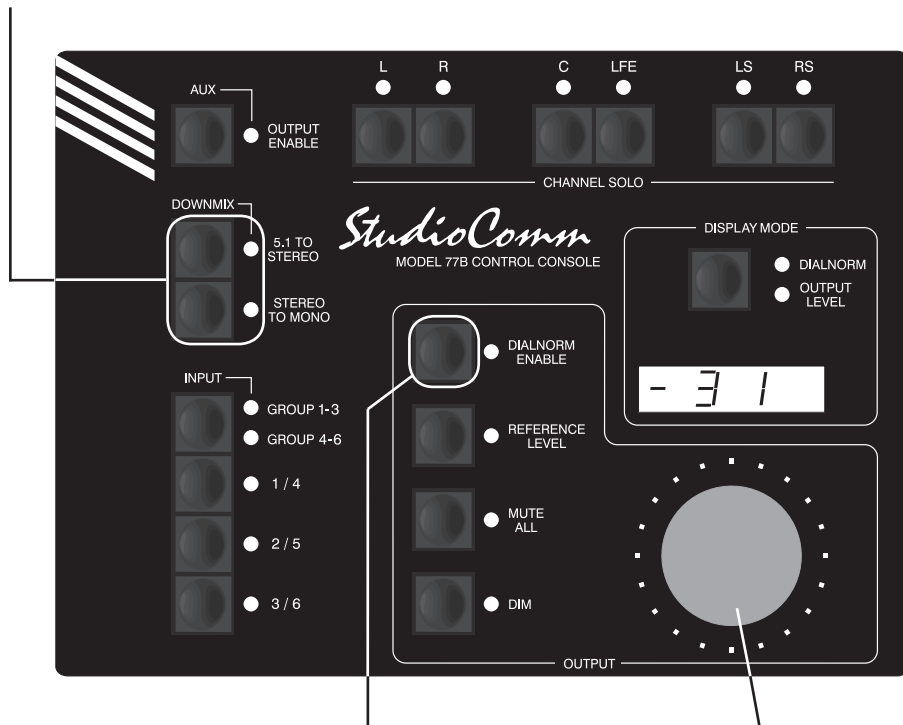

Press and hold the Dialnorm Enable button to display and set the dialnorm reference level and assign the dialnorm data.

Use the level control to adjust the **dialnorm reference level**. The range is -31 to -1 dB in 1-dB steps.

Default: -31 dB dialnorm reference level.
Dialnorm data assigned to surround input A.

Configuration—Dim Level, Remote Mute All, Remote Dim, Remote Auxiliary Stereo Monitor Output On/Off, and Input Delay

This LED displays the configuration of **remote mute all**. LED not lit means remote mute all is disabled; LED lit means enabled. Use the button to change the configuration.

This LED displays the configuration of **remote dim**. LED not lit means remote dim is disabled; LED lit means enabled. Use the button to change the configuration.

This LED displays the configuration of remote auxiliary stereo monitor output on/off. LED not lit means **remote auxiliary stereo monitor output** on/off is disabled; LED lit means enabled. Use the button to change the configuration.

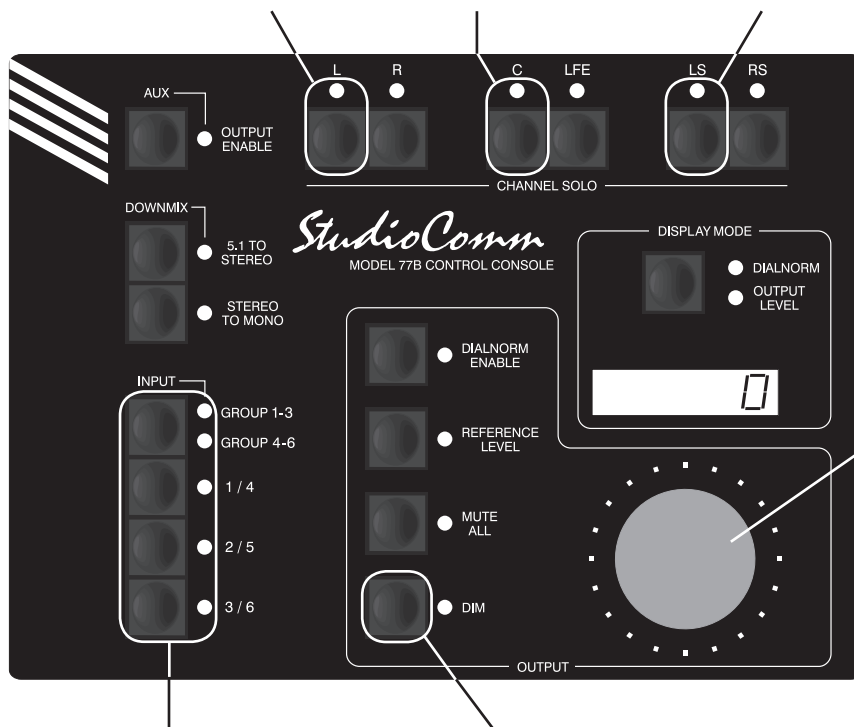

Use the level control to adjust the **input delay**. Range is from 0 to 340. The display shows delay in milliseconds at 48 kHz sampling rate. The value is scaled up or down for other sample rates.

Use these buttons to select **dim level**.
LED Group 1-3 lit means -10 dB;
LED 1/4 lit means -15 dB;
LED 2/5 lit means -20 dB;
LED 3/6 lit means -25 dB.



Press and hold the Dim button and select the dim level, remote mute all, remote dim, remote auxiliary stereo monitor output on/off, and input delay.

Default: -20 dB dim level.
Remote mute all enabled.
Remote dim enabled.
Remote auxiliary stereo monitor output on/off enabled.
Input delay 0 ms.

Configuration—Channel Pop Solo Mode Offset Levels, LFE Downmix Mode, and Pre-Fader Surround Digital Monitor Output Mode



Press and hold the 5.1 to Stereo button to display and select the channel pop solo up offset level, to configure LFE downmix, and configure pre-fader surround digital monitor output mode.



Press and hold the Stereo to Mono button to display and select the channel pop solo down offset level.

When the 5.1 to Stereo button is pressed, these LEDs display the configuration of the **pre-fader surround digital monitor output mode**. LED L lit means outputs are pre-downmix; LED R lit means outputs are post-downmix. Use the buttons to change the configuration.

When the 5.1 to Stereo button is pressed, this LED displays the configuration of the **LFE downmix mode**. LED not lit means LFE downmix mode is disabled; LED lit means enabled. Use the button to change the configuration.

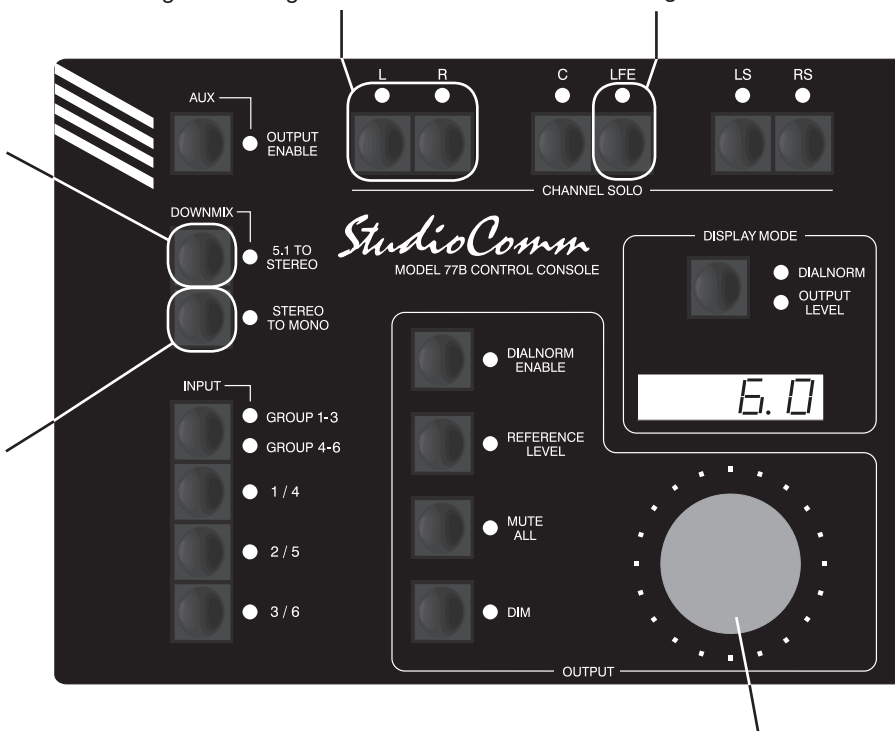

When the 5.1 to Stereo button is pressed, use the level control to adjust the **channel pop solo up offset level**. The range is 0.0 to 12.0 in 0.5-dB steps.

When the Stereo to Mono button is pressed, use the level control to adjust the **channel pop solo down offset level**. The range is -0.0 to -12.0 in 0.5-dB steps and full mute. Full mute is selected by adjusting the level control past -12.0, at which point the display will show - - - -.

Default: 6.0 dB channel pop solo up offset level.
 -6.0 dB channel pop solo down offset level.
 LFE downmix disabled.
 Pre-fader surround digital monitor output pre-downmix.

Configuration—Restore Factory Defaults



Press and hold both the Dialnorm Enable and Dim buttons for 5 seconds to restore Model 77B factory defaults. Once defaults have been restored, the associated LEDs will light. After the buttons are released, configuration mode will be exited and normal operation will resume.

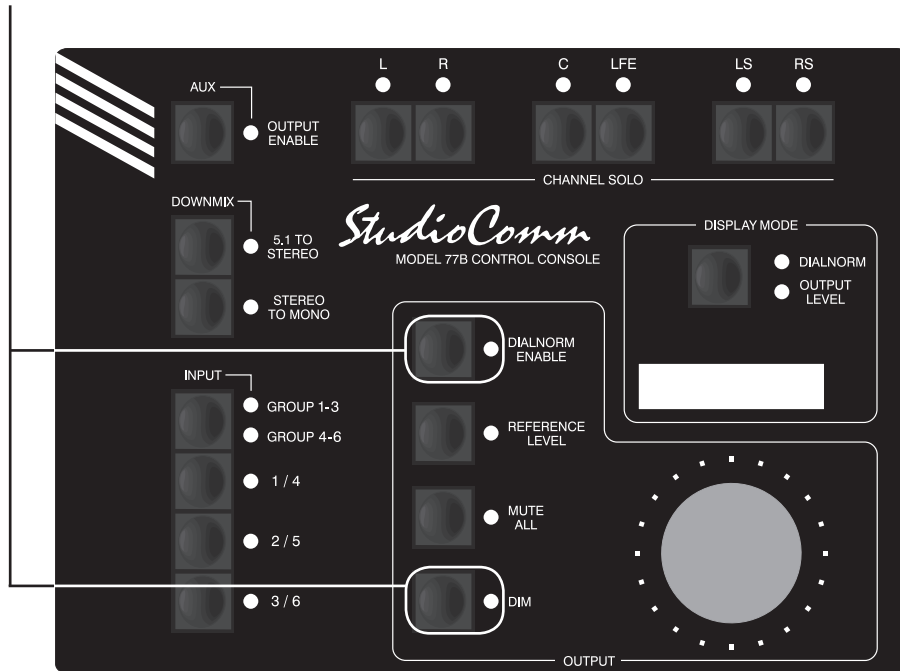

Factory Defaults:

Device address A1.

Stereo input C sample rate converter enabled.

0 dB auxiliary stereo digital and analog monitor output nominal level.

Sync source is L/R of currently selected input.

Sync input terminated.

Audio-synced-to-video sample rate 48 kHz.

Pre-fader surround/stereo input C direct digital monitor output type AES3 (110 ohms/5 Vpp).

Post-fader surround/auxiliary stereo digital monitor output type AES3 (110 ohms/5 Vpp).

Surround input A assigned to input 1.

Surround input B assigned to input 2.

No input assigned to input 3 (disabled).

Stereo input A assigned to input 4.

Stereo input B assigned to input 5.

Stereo input C assigned to input 6.

–60.0 dB post-fader surround digital and analog reference output level.

Attenuation display mode selected.

85.0 dB SPL reference level.

–31 dB dialnorm reference level.

Dialnorm data assigned to surround input A.

–20 dB dim level.

Remote mute all enabled.

Remote dim enabled.

Remote auxiliary stereo digital and analog monitor output on/off enabled.

Input delay 0 ms.

6.0 dB channel pop solo up offset level.

–6.0 dB channel pop solo down offset level.

LFE downmix disabled.

Pre-fader surround digital monitor outputs pre-downmix.

Warning: Each Model 77B unit must have a unique address. Restoring factory defaults will reset only this specific Model 77B to address A1. If another connected unit is already configured for address A1, normal system operation will stop.

Note: The 5-second button-press delay is a safety feature ensuring that the factory defaults will not be accidentally restored.

Operation

Now that you've installed and configured the system, you're ready to go. You should find operation very easy. However, taking time to study this section of the guide may prove valuable.

Upon power up the system will return to the last operating condition, including the selected source, downmix modes, etc. As a precaution, however, the post-fader surround digital and analog monitor output levels will always return to their minimum value. The rotary level control or the reference level button must then be used to return the system to the desired monitor output level.

Model 76DBA Central Controller

The Model 76DBA's front panel contains three LEDs. The control console status LED will light whenever the Model 76DBA is communicating with the one or more connected Model 77B or Model 71 units. A flashing control console status LED will indicate that the DC power output supporting the control consoles is in a short-circuit or over-current condition. The control console status LED will not light when a Model 77B is in the configuration mode or when the Model 77B is going through its power-up sequence.

The metadata status LED will light whenever an active metadata signal has been connected and valid metadata sync word information is being received.

The sync status LED will light whenever a valid timing reference signal is being received by the Model 76DBA. A flashing sync status LED indicates that a valid sync signal is not being received.

Control Consoles

StudioComm for Surround operation is controlled using the up to four Model 77B or Model 71 Control Consoles that have been connected. Two system functions can also be controlled by means of the remote control inputs.

Model 77B Control Console

To make things easy to describe, the Model 77B's operator functions are divided into seven main groups: input source selection, downmix, monitor output general functions, channel solo, auxiliary stereo monitor outputs, display and display mode, and remote control inputs.

Any change made to any one Model 77B unit will be reflected in the LEDs and displays on all the connected units. Note that all control consoles function simultaneously—there is no priority of one unit over the others.

Input Source Selection

Four input select buttons work together to allow pre- and post-fader monitoring of up to six input source configurations. One button serves as a group select while the other three select the specific input. The group select button is used to select the active group, alternating between groups 1-3 or 4-6. Two LEDs are associated with this button and indicate which group is active. The other three buttons are used to select the specific input source to be monitored. The choices are 1/4, 2/5, and 3/6, with the active input following the status of the group select function. LEDs are associated with the input select buttons and indicate which is active. Note that the Model 77B "remembers" which specific input was last selected for each group, so changing

between groups will switch between two specific inputs. This allows rapid switching between, for example, input 1 and input 6.

The specific sources assigned to the input buttons depend on the signals connected to the Model 76DBA along with how the system has been configured. Any input can be assigned to any input select button. (Technically, the same input could be assigned to multiple buttons!) This means, for example, that a surround input could be monitored using any of the input select buttons. The same holds true for a stereo, dual channel, or monaural input source.

Downmix

Two downmix functions allow users to perform “real-world” audio format compatibility checks. One function allows a surround (5.1) signal to be “folded down” (mixed) to stereo. The other allows a stereo signal to be converted to mono. Using the downmix functions simply requires pressing the desired button. The buttons are set to always “latch” the functions on and off. An LED is located adjacent to each button and lights whenever its respective function is active. The downmix functions always impact the post-fader surround digital and analog monitor outputs. And, depending on the selected configuration, they may also impact the pre-fader surround digital monitor output. Please refer to the Specifications section of this guide if you’d like a detailed description of how the downmix functions perform their tasks.

A specific downmix function can only be enabled when it is applicable for the currently selected input source. This means that the 5.1 to stereo downmix function can only be enabled when surround input A or B is selected.

The Model 77B associates the state of the downmix functions with the currently selected input. For example, if surround input A is the selected input source and the 5.1 to stereo downmix function is enabled, this condition will be “remembered” when switching to one of the stereo input sources. Upon returning to surround input A, the 5.1 to stereo downmix function will again become active.

5.1 to Stereo

When the 5.1 to stereo downmix function is enabled the LS, RS, and C channels associated with a surround source are combined (“folded down”) with the L and R signals to create a 2-channel stereo (left and right) signal. And, depending on the system’s configuration, the LFE channel may also be combined with the L and R signals. The resulting stereo signal, sometimes known as LoRo, is routed to the L and R surround digital and analog monitor output channels. The C, LFE, LS, and RS digital and analog monitor output channels are muted. By utilizing this downmix function phase relationships and inter-channel level issues can be quickly observed.

Stereo to Mono

The stereo to mono downmix function combines the L and R audio channels to create a single-channel monaural signal. This signal is sent out the C surround digital and analog monitor output channels while the L, R, LS, RS, and LFE digital and analog monitor output channels are muted.

When a surround source has been selected for monitoring, the 5.1 to stereo downmix function will automatically enable whenever the stereo to mono downmix function is enabled. This ensures that an operator will hear a mono signal created

by folding down all channels associated with the selected surround input.

Monitor Output General Functions

Four buttons and one rotary control are associated with the post-fader surround digital and analog monitor output functions. The buttons control operation of the reference level, mute all, dim and dialnorm enable functions. The rotary level control is used to manually set the post-fader surround digital and analog monitor output levels. These buttons and the rotary control do not impact the pre-fader surround and stereo input C direct digital monitor outputs.

Reference Level

The reference level button sets the post-fader surround digital and analog monitor output levels to a preset value. Technical personnel, using a sound-pressure-level (SPL) meter and precision signal source, should have set this level to meet the requirements of the specific monitoring environment. The LED associated with the reference level button will light whenever the function is active. The 4-digit display will indicate the reference output level. Note that the system's default reference level is -60.0 dB so "out of the box" the Model 77B will display **-60.0** when reference level mode is enabled.

The LED associated with the reference level button can also serve as a calibration aid. If the reference level mode is not active, whenever the post-fader surround digital and analog monitor output levels are precisely the same as that stored for the reference value the reference level LED will flash. This exact level can be reached

through the use of the rotary level control, either by itself or through the setting of the rotary level control in conjunction with the dim function. Whatever path the post-fader surround digital and analog monitor outputs takes to reach the reference level value, it will cause the reference level LED to flash!

Mute All

Pressing the mute all button causes the output channels associated with the post-fader surround digital and analog monitor outputs to mute. The 4-digit display indicates the mute condition by showing four dashes (— — — —). The mute all button is always set to "latch" the function on and off. The LED associated with the mute all button will light whenever mute all is active. Note that if mute all is enabled via the remote mute all function, the mute all LED will flash.

Dim

The dim function is provided for user convenience, allowing the post-fader surround digital and analog monitor output levels to be reduced by a fixed amount. The Model 77B's configuration mode allows the dim level to be selected from among four choices: -10.0 , -15.0 , -20.0 , or -25.0 dB. Pressing the dim button will enable the function. The dim button is always set to "latch" the function on and off. The 4-digit display, when selected for output level mode, will indicate the revised post-fader surround digital and analog monitor output levels. If the requested "dimmed" output level is equal to or less than -96.0 dB, the post-fader surround monitor outputs will go into full mute and the display will show four dashes (— — — —). When dim is active the post-fader monitor output level reduction will apply no matter whether the level is

being set by the rotary level control or by the reference level button. The LED associated with the dim button will light whenever dim is active. If dim mode is enabled via the remote dim function the dim LED will flash.

It's worth using a few sentences to discuss the auto dim off function. Whenever dim is enabled due to the dim button being pressed, and the rotary level control is active (reference level mode is not active), changing the setting of the rotary level control will automatically turn off dim. The auto dim off function is a unique attempt at protecting the aural health of users. No longer will there be a heart-stopping blast of audio when the dim button is pressed, supposedly to enable dim, but actually turning dim off because it was already enabled. It's hard to explain unless you've experienced this in person—trust us, this situation can and does happen!

Note that the auto dim off function is not active whenever dim is enabled due to the remote dim function being active. This allows remote control equipment, such as a talkback system, to reliably dim the monitor outputs.

Dialnorm Enable

Enabling the dialnorm level function simply requires pressing the dialnorm enable button. The button provides a “latching” function so that the selected state is maintained. An associated LED will light whenever the function is active. The dialnorm enable function can only be activated when the selected input source is the surround signal that has been configured as having dialnorm associated with it. (This is because dialnorm level data is available only for that specific source.) When enabled, as the dialnorm level changes

the post-fader surround digital and analog monitor output levels will automatically increase or decrease as appropriate. During configuration of the system a dialnorm reference level was entered. This level, typically in the range of -27 to -24 dB, is compared to the incoming dialnorm level value. If the current dialnorm level is less than the reference value the output level is increased by the difference. If the current dialnorm level is greater than the reference value the output level is decreased, again by the difference. Note that dialnorm levels are limited to a range of -31 to -1 dB. This restricts the maximum amount of level control to 30 dB.

The 4-digit display, when selected for output level display mode, will display all level changes as they occur, including level changes due to dialnorm activity. The current dialnorm level value can itself be viewed by selecting the display dialnorm mode.

In either display mode the decimal point “dot” in the lower-right corner of the 4-digit display will light whenever the current dialnorm value matches the dialnorm reference value. This topic is described in greater detail in the Display and Display Mode section later on in this section. The Technical Notes section of this guide also will provide additional useful information about dialnorm.

Rotary Level Control

The rotary level control is used to manually adjust the post-fader surround digital and analog monitor output levels. The level control provides the ability to adjust the post-fader surround digital and analog monitor output levels over a 70 dB range. Technically the rotary level control is a 24-step-per-revolution mechanical encoder.

The amount of level change in dB per step (“click”) will depend on how quickly the control is turned. When rotated slowly, each step represents a 0.5-dB change in level. In this case, to traverse the entire level range would require rotating the control more than five full turns. But the Model 77B’s software detects when the control is rotated more quickly and increases the amount of level change in dB per step. A little experimentation will allow the user to acquire a good “feel” for how best to use the control.

The reference level LED will flash when the rotary level control sets the output level to be the same as the stored reference level. Whenever the rotary level control attempts to set the output level for less than -70.0 dB, the post-fader surround digital and analog monitor output channels will automatically mute. As previously discussed, the 4-digit display indicates the mute condition by showing four dashes (----).

If the mute all function is active the rotary level control won’t have an impact on the post-fader surround digital and analog monitor output levels. It’s also not active whenever the reference level function is active, except if the auto reference level off function has been enabled.

Channel Solo

The channel solo function allows specific channels to be selected for individual or group “solo” monitoring. The function impacts the post-fader surround digital and analog monitor outputs, taking place electrically “after” the source selection, input delay, downmix, and level control functions. Two solo modes are available, normal and channel pop. In the normal solo mode

the level of a channel selected for soloing actually doesn’t change; the solo function causes the non-soloed post-fader surround monitor output channels to mute. In the channel pop solo mode the level of the soloed channel will increase, while the level of the non-soloed channels will decrease. In this way the soloed channel will “pop out” from an audio mix so as to be more easily observed. The actual level changes that occur in pop solo are dependent on how the system has been configured.

Six buttons and associated LEDs, along with the auxiliary stereo monitor output enable button, are associated with the channel solo function. To solo a channel simply requires pressing one of the solo buttons. The buttons function in a press-to-enable/press-to-disable “latching” mode. The LED associated with a soloed channel is used to indicate that solo is active.

The auxiliary stereo digital and analog monitor output enable button is used to select the solo mode. Using this button the solo mode can be changed any time between normal and channel pop. Simply press and hold the auxiliary stereo digital and analog monitor output enable button for a few seconds until the channel solo LEDs light in the desired manner; steady to indicate normal solo mode and flashing for channel pop solo mode. Once the state of the LEDs change (steady-to-flashing or vice-versa) the desired solo mode becomes active and the button can be released. The selected solo mode will be maintained even after the system is powered down and subsequently powered up. In the normal solo mode a soloed channel will have its associated LED light steadily. In the channel pop solo mode a soloed channel will have its associated LED flash.

For user flexibility, more than one output channel can be selected for soloing at a time. The Model 77B even allows all six surround digital and analog monitor output channels to be simultaneously selected for solo. This would seem to be an “all soloed so none are soloed” mode. But this condition is specifically allowed so that when in the normal solo mode an output channel mute function can be provided. By first soloing all output channels an operator can then “un-solo” specific channels, directly muting them. It’s a bit confusing to describe in words but is very simple to use and can be a very useful resource—try it out and you’ll see! But note that while you can always solo all channels, it’s really more useful to do this when the system is configured for normal solo mode. If selected for the channel pop solo mode, soloing all the channels won’t provide a very useful function.

Auxiliary Stereo Monitor Outputs

As has been previously discussed in this user guide, the auxiliary stereo digital and analog monitor outputs are stereo (2-channel) outputs that can be used for special applications. The source for these outputs is stereo input C. Using the auxiliary stereo monitor output enable button stereo input C can be routed to these outputs as desired. The button functions in an alternate action manner to change the current state of the outputs. An associated LED lights whenever the auxiliary stereo digital and analog monitor outputs are active. No level control, downmix, or other Model 77B-supported functions will impact the auxiliary stereo monitor outputs.

Display and Display Mode

The Model 77B’s 4-digit LED display can be selected to show either the level of the post-fader surround digital and analog monitor outputs or the dialnorm level. The display mode button is used to select the desired mode. Two LEDs are associated with this button, indicating which mode is active. The button can also be used to display the Model 76DBA’s current sample rate.

Both level modes will indicate level in dB. What the digits actually represent will depend on how the Model 77B has been configured. When selected for the output level display mode, the post-fader surround digital and analog monitor output levels will be shown as either the amount of attenuation or the sound pressure level (SPL).

Display in dB of Attenuation

If configured for the attenuation mode the display will show the post-fader surround digital and analog monitor output levels as an attenuation value in reference to the maximum output. This is in the form of 0.5-dB steps less than the maximum of 0.0 dB. So a display of –40.5 would indicate that the surround digital and analog monitor outputs are set to be 40.5 dB below the maximum level. As the rotary level control is turned counterclockwise the output level will go down and the indicated value will get more negative.

Display in dB SPL

If the Model 77B is configured to display the post-fader surround digital and analog monitor output levels in dB SPL, the 4-digit display will always show the output level in positive numbers. These numbers

are intended to represent the sound pressure level in dB SPL, a figure that should directly relate to the actual sound pressure level that the surround loudspeaker system is presenting to users. (Typically, the level value would actually be in dBC, the C-weighted sound pressure level.) When the reference level button is enabled, or the rotary level control is set so that the reference level has been reached, the display will typically show something in the range of 82 to 87 dB. Assuming that the monitoring environment has been correctly calibrated, this would indicate that an average listening level of 85 dB, for example, had been achieved.

Dialnorm Display

When the 4-digit display is set for the dialnorm display mode a much different piece of information will be shown to the user. It will show the somewhat obscure but important dialnorm level parameter that's associated with a surround input source. As has been covered in other parts of this user guide, dialnorm is intended to provide a numeric value that represents the average dialog level associated with an audio-for-picture element. Technically, dialnorm values can range from -31 to -1 dB but during actual operation they will typically be in the range of -30 to -20 dB. The value may change relatively frequently in conjunction with changes to the actual audio signal level. This would be the case, for example, with a television program that consists of alternating program and advertising segments. In other situations the dialnorm level will only change when an "on-air" source is switched from typical station-originated segments to an extended-duration broadcast network program, such as a live

concert event. It's also possible that in some facilities the dialnorm level is fixed and won't ever change. That's not really in the spirit of what dialnorm is supposed to accomplish, but c'est la vie. Whatever the dialnorm level—the Model 77B will display it!

In both display modes a special feature is provided to assist users in knowing if the current dialnorm level matches a facility's "house" reference. This reference level, typically in the range of -24 to -27 dB, is entered as part of the Model 77B's configuration process. The "dot" in the lower-right corner of the 4-digit display will light whenever the current dialnorm level matches the stored reference level. Refer to Figure 10. This feature can be useful in broadcast transmission and distribution applications. In theory, any time the dot in the lower-right corner is not lit the current dialnorm level value is causing a level adjustment to take place. This level adjustment may be taking place on the post-fader surround digital and analog monitor outputs if the dialnorm enable function is active, as it would be for downstream users of the broadcast signal.

Note that if a valid dialnorm source is not available the 4-digit display, when selected to display dialnorm, will show four dashes

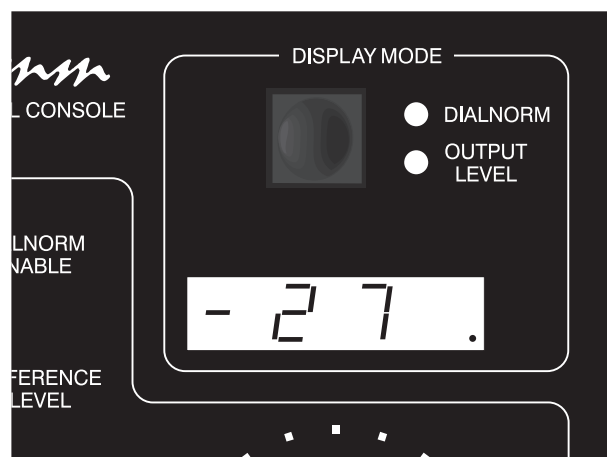

Figure 10. Incoming Dialnorm Level Match "Dot"

(---). This could be due to a problem with the metadata signal connected to the Model 76DBA Central Controller. But more frequently this will simply be the normal result that occurs when the Model 77B's input is not selected for the metadata-associated surround input source.

Channel Pop Solo Display

As has been previously discussed, the channel pop solo mode offers a unique way of sonically highlighting an individual channel. A channel selected for soloing in this mode will have its level increased while the other non-soloed channels will be reduced in level. To highlight this condition the letters **POP** will appear in the 4-digit display whenever a channel is actively being soloed in the channel pop solo mode. This ensures that a user will understand that the post-fader surround digital and analog monitor outputs no longer represent the true inter-channel level relationships.

Display Current Sample Rate

Pressing and holding the display mode button will cause the current sample rate value to be displayed: **32.0**, **44.1**, **48.0**, **88.2**, **96.0**, **176.4**, or **192.0**. This can be useful during troubleshooting or just for general interest. Once the button is released normal display operation will resume.

Remote Control Inputs

As previously discussed in the Installation section of this user guide, three remote control signals can be connected to the Model 76DBA and then configured for operation. The functions are remote mute all, remote dim, and remote auxiliary stereo monitor output on/off. When an external

signal activates remote mute all the LED on the Model 77B associated with the mute all button will flash. If mute all was already active when the remote mute all function is activated, the LED will change from being steadily lit to flashing.

When an external signal activates remote dim the LED on the Model 77B associated with the dim button will flash. If dim was already active when remote dim is activated, the LED will change from being steadily lit to flashing.

When an external signal activates the remote auxiliary stereo monitor outputs the LED associated with the auxiliary stereo monitor output enable button will flash. If the auxiliary stereo monitor output was already active when remote auxiliary stereo monitor output on/off is activated, the LED will change from being steadily lit to flashing.

Model 71 Control Console

The Model 71 Control Console provides a limited number of pushbutton switches, LEDs, and a rotary level control for status display and control. The two buttons, along with associated LEDs, provide access to the dim and reference level functions. A rotary level control allows adjustment of the post-fader surround digital and analog monitor output levels. A status LED lights steadily whenever normal Model 71 operation is taking place.

Any changes made using the Model 71's rotary level control and buttons will be reflected in the appropriate LEDs and displays on all the connected Model 77B and Model 71 units. And, as expected, changes made using a Model 77B will be reflected in the Model 71's LEDs.

Rotary Level Control

The rotary level control is used to manually adjust the post-fader surround digital and analog monitor output levels. Its operating characteristics are identical to those of the Model 77B Control Console, discussed earlier in this section.

Dim

The dim function allows the post-fader surround digital and analog monitor output levels to be reduced by a fixed amount. Its operating characteristics are identical to those of the Model 77B Control Console, discussed earlier in this section.

Reference Level

The reference level button sets the post-fader surround digital and analog monitor output levels to their preset values. The operating characteristics are identical to those of the Model 77B Control Console, discussed earlier in this section.

Technical Notes

Loss of Sync

The Model 76DBA relies on an external timing reference (sync) source for proper operation. This can be in the form of an AES3id, word clock, DARS (AES11), bi-level video, or tri-level video reference signal. In most cases the sync signal will be connected to the sync input BNC connector located on the Model 76DBA's back panel. Alternately, a configuration choice allows the L/R input of the AES3id source currently selected for monitoring to also serve as the system's timing reference. Whenever a valid sync signal has been connected to the Model 76DBA the sync status LED, located on the unit's front panel, will light. The sample rate of the

monitor output channels will reflect the rate of the sync input and, if a video sync source is utilized, the configured rate.

If a valid sync signal is not present several visual indications are provided. On the Model 76DBA the sync status LED will flash. On all connected Model 77B Control Consoles the 4-digit LED display will cease normal operation, instead alternating between the words **no** and **sync**. When a valid sync signal is again connected the Model 76DBA's sync status LED will light steadily. On the Model 77B units the word **sync** will momentarily be displayed followed by a brief display of the digital monitor output sample rate. The sample rate will display as **32.0**, **44.1**, **48.0**, **88.2**, **96.0**, **176.4**, or **192.0**, reflecting the impact of the sync source rate and the Model 76DBA's configuration.

If during normal operation the sync source changes from one valid rate to another a visual indication is provided. On the Model 77B units the new sample rate—**32.0**, **44.1**, **48.0**, **88.2**, **96.0**, **176.4**, or **192.0**—will momentarily be displayed.

Any time that a valid sync signal is not connected to the Model 76DBA the digital monitor outputs will automatically revert to an internally generated sample rate of 48 kHz with no digital audio content present. This audio "black" signal will allow most connected equipment to continue to function correctly, of course with no meaningful audio signal present. The analog monitor outputs will move to their minimum output condition. As soon as a valid sync signal is again connected to the Model 76DBA the digital monitor outputs will automatically switch to their correct sample rate and audio signals will again be present. The analog monitor outputs will return to their normal signal levels.

Power Down

Great care was taken in the Model 76DBA's design to minimize the chance that clicks, pops, or other objectionable audio signals will be present on the digital and analog monitor outputs. A power-down circuit supplies the main microcontroller integrated circuit with an indication that a power loss is imminent. When this condition is detected the digital monitor outputs will switch to silence (audio "black") in preparation for a complete loss of signal. Electromechanical relays associated with the analog monitor outputs will change to their mute state to minimize the change of signal transients reaching the connected inputs.

Power-Up Messages and Error Codes

Upon mains power being applied to the Model 76DBA all connected Model 77B units will go through a power-up sequence. The sequence starts by each of the individual LEDs lighting in a "walk-through" sequence. Then the 4-digit display tests all its LED segments. Finally, a set of messages provide details on the specific Model 77B and connected Model 76DBA software versions:

1. Displays **77B**
2. Displays Model 77B's software version
3. Displays Model 77B's unit address (**A1**, **A2**, **A3**, or **A4**)
4. Displays **76db**
5. Displays Model 76DBA's main software version
6. Displays **FPgA**
7. Displays Model 76DBA's logic device (FPGA) software version

After a successful system power-up sequence normal operation will then commence. Should a problem be encountered during power up one of two error codes may show on the Model 77B's 4-digit display. If **Err1** displays it indicates that communication is not taking place with the Model 76DBA. The most likely cause would be incorrect wiring of the data pair linking the two units. **Err2** indicates that the Model 76DBA is having problems with its internal logic device. (A high-speed field-programmable gate array (FPGA) serves as the digital "heart" of the Model 76DBA and without it no audio activity can occur.) The only way to remedy this condition is to first try removing and reconnecting mains power. (And that's a long-shot as to whether it would accomplish anything.) If the error code continues to be displayed the Model 76DBA must be returned to the factory for service. Note that for the vast majority of StudioComm systems neither of these error codes, especially **Err2**, will ever appear.

Sample Rate Conversion (SRC)

Circuitry associated with stereo input C can provide sample rate conversion (SRC) capability. A digital audio signal connected to that input can have its sample rate and timing re-synchronized to match the Model 76DBA's internal timing. While it would be nice to proclaim that the engineers at Studio Technologies came up with a unique and exotic circuit to perform this function it's really not the case. Several semiconductor companies provide "single-chip" SRC solutions and an excellent one from AKM was selected for the Model 76DBA. The technical capabilities of the Model 76DBA's SRC function is stated in

this way: the sample rate of an input signal can range from 1/6 to six times the Model 76DBA's output sample rate, with the additional restriction that it must be no less than 8 kHz and no more than 216 kHz. The Model 76DBA's output sample rate is determined by the selected timing reference (sync) signal and, if required, a configured value. If a word clock, DARS (AES11), or AES3id signal is the designated sync source its rate will be the Model 76DBA's output sample rate. If a video sync signal is connected, the Model 76DBA's sample rate is selected as part of the configuration process.

So in practice what can the SRC function accomplish? If the output sample rate is 48 kHz then a signal connected to stereo input C can have a sample rate from 8 to 216 kHz. Or, as another example, if the Model 76DBA's output sample rate is 96 kHz a signal connected to stereo input C can have its sample rate range from 16 to 216 kHz.

As useful as allowing one disparate sample rate to be converted to another, it may be the ability of the Model 76DBA's SRC function to re-synchronize a signal that proves most valuable. For example, in typical post-production and broadcast applications all signals will have a sample rate of 48 kHz. A Model 76DBA and all of its normally connected input signals will be "locked" to the main timing reference signal that supports the 48 kHz sampling rate. But, as an example, a signal associated with a portable device, while at a 48 kHz sampling rate, may not be synchronized ("genlocked") to the "house" reference. Connecting this signal to stereo input C will cause the SRC function to "lock" it to the Model 76DBA's rate, thus allowing it to be monitored over a loudspeaker

system. In addition, the stereo input C direct digital monitor output can be connected to other devices that find need for the now-synchronized signal. In some cases it may be useful to connect the stereo input C direct digital monitor output to the input of a signal router, allowing an entire facility to access the signal.

Model 76DBA to Control Console Connections

Figure 7 gives a detailed description of the signals that connect the Model 76DBA Central Controller to the one or more Model 77B or Model 71 Control Consoles. The Model 76DBA provides a +12 volt DC power source for use by the control console's circuitry. The DC output is current-limited to minimize the chance that a short-circuit condition will damage the Model 76DBA's circuitry. An asynchronous, bi-directional data interface links the connected units. The RS-485 hardware connection scheme operates at a rate of 115.2 Kbit/s and uses an 8-N-1 data format. The Model 76DBA communicates with each Model 77B and Model 71 unit 20 times per second, receiving button and rotary level control information and sending LED and 4-digit display status data.

"Hot" Disconnection of Control Consoles

There's no problem relocating one or more Model 77B or Model 71 Control Consoles while the StudioComm system is operating. You can disconnect the 9-pin interconnecting cable, move the unit (or units), and then reconnect without issue. Upon disconnection of all control consoles the Model 76DBA Central Controller will mute the internal digital audio channels as well

as save the current operating parameters. No clicks, pops, or other noises will occur when the Model 77B or Model 71 units are again connected. The control consoles will go through their standard power-up sequence and then normal operation will resume.

Channel Status, User, and Validity Bits

The non-audio bits that are part of the AES3/AES3id digital monitor output channel data are actively controlled by the Model 76DBA's software. The Channel Status bits use the Professional Use of Channel Status block. They indicate a word length of 24 and the current sample rate. The correct CRC is also calculated and inserted. The User bits are always set to 0. When a valid timing reference (sync) source is recognized by the system the Validity bits will be set to 1.

The Model 76DBA's hardware is capable of routing the C/U/V bit information from any of the L/R inputs, as well as the sync input, to the main logic device (FPGA) and then on to the digital audio transmitter (DIT) integrated circuits. This is provided for future use and is not active at this time.

Specifications

Model 76DBA Central Controller

General Audio:

Supported Sample Rates: 32, 44.1, 48, 88.2, 96, 176.4, and 192 kHz

Word Length: 24 bits maximum

Internal Processing: 32 bits

Input-to-Output Latency: one sample (e.g., 0.021 milliseconds @ 48 kHz sample rate)

Digital Audio Inputs: 5 (18 audio channels)

Configuration: two surround (5.1) and three stereo

Type: AES3id-2001/SMPTE 276M (unbalanced 75 ohms/1 Vpp)

Connectors: BNC (per IEC 60169-8 Amendment 2)

Sample Rate Conversion (SRC):

Application: available on Stereo Input C

Input Sample Rate Range: 8 to 216 kHz, limited to 1/6 to 6 times the output sample rate

Latency: 1 millisecond, nominal

Sync Source: configured to follow L/R of currently selected input or signal connected to sync input

Sync Input:

Compatible Sources: word clock, DARS (AES11), bi-level video, tri-level video

Jitter: 4 ns pp maximum

Connector: BNC (per IEC 60169-8 Amendment 2)

Termination: 75 ohms, selectable on/off

Digital Monitor Outputs: 16 (8 pairs)

Configuration: organized as two surround (5.1), one auxiliary stereo, and one stereo input C direct

Dynamic Range: 135 dB

Type: AES3 (110 ohms/5 Vpp) or AES3id/SMPTE 276M (75 ohms/1 Vpp), selectable

Connector: 25-pin D-subminiature female (DB-25F)

Analog Monitor Outputs: 8

Configuration: organized as one surround (5.1) and one auxiliary stereo

Type: electronically balanced, source impedance 200 ohms

Nominal Level: +4.0 dBu @ -20 dBFS input source and level control at maximum setting

Maximum Level: +24 dBu into 2000 (2 k) ohms or greater

Frequency Response, Digital Inputs to Analog Monitor Outputs: 10 Hz-20 kHz +0.0/-0.3 dB @ 48 kHz sample rate; -3 dB @ 64 kHz

Distortion (THD+N): 0.004%, ref 1 kHz, +4 dBu output

S/N Ratio: 89 dB, ref +4 dBu output

Dynamic Range: greater than 109 dB

Crosstalk: 98 dB at 1 kHz; 97 dB at 16 kHz, ref -1 dBFS input

Connector: 25-pin D-subminiature female (DB-25F)

Configurable Delay: 0 to 340 milliseconds @ 48 kHz sample rate (scales up or down depending on actual sample rate)

Downmix:

Functions: 5.1 to stereo, stereo to mono

5.1 to Stereo: LS @ -3 dB summed with L
RS @ -3 dB summed with R

C @ -6 dB summed with L and R

LFE @ -6 dB summed with L and R (if enabled)

C, LFE, LS, and RS monitor outputs mute

Stereo to Mono: L @ -3 dB summed with R
@ -3 dB to C

L, R, LS, RS, and LFE monitor outputs mute (for a surround input this results in the C output being the sum of L @ -3 dB, R @ -3 dB, C @ -3 dB, LFE @ -3 dB (if enabled), LS @ -6 dB, and RS @ -6 dB)

Control Console Interface:

Type: RS-485, 115.2 Kbit/s, 8-1-N

Polling Interval: 50 milliseconds

Power: 12 volts DC, 500 milliamperes maximum

Connector: 9-pin D-subminiature female (DE-9F)

Dolby E Metadata Input:

Type: RS-485/RS-422

Data Rate/Format: 115.2 Kbit/s, 8-N-1

Connector: 9-pin D-subminiature female (DE-9F), shared with remote control inputs

Remote Control Inputs: 3

Functions: remote mute all, remote dim, remote auxiliary stereo monitor output on/off

Type: +5 V logic, activates on closure to system common

Connector: 9-pin D-subminiature female (DE-9F), shared with metadata input

AC Mains:

Requirement: 100 to 230 V, +10/-15%, 50/60 Hz, 15 W maximum

Connector: 3-blade, IEC 320 C14-compatible (mates with IEC 320 C13)

Dimensions:

19.00 inches wide (48.3 cm)

1.72 inches high (4.4 cm)

7.00 inches deep (17.8 cm)

Mounting: one space (1U) in a standard 19-inch rack

Weight: 6.2 pounds (2.8 kg)

Model 77B Control Console

Application: up to four Model 77B Control Consoles can be connected to a Model 76DBA Central Controller

Power: 12 volts DC nominal (9 volts DC minimum), maximum current 100 milliamperes, provided by Model 76DBA Central Controller

Control Data:

Type: RS-485

Data Rate/Format: 115.2 Kbit/s, 8-N-1

Connector: 9-pin D-subminiature female (DE-9F)

Dimensions (Overall):

7.20 inches wide (18.3 cm)

2.20 inches high (5.6 cm)

5.40 inches deep (13.7 cm)

Weight: 1.7 pounds (0.8 kg)

Model 71 Control Console

Application: up to three Model 71 Control Consoles can be connected to a Model 76DBA Central Controller

Power: 12 volts DC nominal (9 volts DC minimum), maximum current 35 milliamperes, provided by Model 76DBA Central Controller

Control Data:

Type: RS-485

Data Rate/Format: 115.2 Kbit/s, 8-N-1

Connector: 9-pin D-subminiature female (DE-9F)

Dimensions (Overall):

3.20 inches wide (8.1 cm)

2.20 inches high (5.6 cm)

4.10 inches deep (10.4 cm)

Weight: 0.8 pounds (0.4 kg)

Specifications and information contained in this User Guide subject to change without notice.

Appendix A—Connection Pin-Out Charts

Connections	TASCAM® Channel	Signal High (+)	Signal Low (–)	Shield
Pre-Fader L/R	1	24	12	25
Pre-Fader C/LFE	2	10	23	11
Pre-Fader LS/RS	3	21	9	22
Stereo Input C Direct	4	7	20	8
Post-Fader L/R	5	18	6	19
Post-Fader C/LFE	6	4	17	5
Post-Fader LS/RS	7	15	3	16
Auxiliary Stereo	8	1	14	2

Notes: 1) All signals transformer-coupled digital audio; selectable for AES3 or AES3id compatibility.

2) Connector type on Model 76DBA is 25-pin D-subminiature female (DB-25F). Installer must provide male (DB-25M). Connector uses 4-40 threaded inserts for locking with mating plug.

3) Wiring scheme follows TASCAM DA-88 convention. Standard DA-88-type wiring harnesses are directly compatible, with the possible exception of 4-40 screw threads being required.

Connections for Digital Monitor Outputs

Connections	Signal High (+)	Signal Low (–)	Shield
Surround L	24	12	25
Surround R	10	23	11
Surround C	21	9	22
Surround LFE	7	20	8
Surround LS	18	6	19
Surround RS	4	17	5
Auxiliary Stereo L	15	3	16
Auxiliary Stereo R	1	14	2

Notes: 1) Connector type on Model 76DBA is 25-pin D-subminiature female (DB-25F). Installer must provide male (DB-25M). Connector uses 4-40 threaded inserts for locking with mating plug.

2) Wiring scheme follows TASCAM DA-88 convention. Standard DA-88-type wiring harnesses are directly compatible, with the exception of 4-40 screw threads being required.

Connections for Analog Monitor Outputs

Signal	Pin	Direction
Data + (RS-485/RS-422)	7	Input
Data – (RS-485/RS-422)	2	Input
Data Shield	1	Shield
Remote Mute All	5	Input
Remote Dim	6	Input
Remote Aux Stereo Monitor Out On/Off	8	Input
Remote Spare	9	Input
Remote Common	4	Common

Note: Connector type on Model 76DBA is 9-pin D-subminiature female (DE-9F). Connector uses 4-40 threaded inserts for locking with mating plug.

Connections for Metadata and Remote Control Inputs

Signal	Pin	Direction
Data + (RS-485)	1	To/From Models 77B/71
Data – (RS-485)	6	To/From Models 77B/71
Data Shield	2	To/From Models 77B/71
DC + (12 V)	4	To Models 77B/71
DC – (12 V Return)	9	To Models 77B/71
DC Power Shield	5	To/From Models 77B/71

Note: Connector type on Model 76DBA is 9-pin D-subminiature female (DE-9F). Connector uses 4-40 threaded inserts for locking with mating plug.

Connections between Model 76DBA and Model 77B and Model 71

Appendix B—Sync Input Sources

The Model 76DBA’s sync input has been tested and confirmed for correct operation with the following sync signals:

Word Clock: Square wave signal with rate of 32, 44.1, 48, 88.2, 96, 176.4, or 192 kHz.

DARS (AES11) or AES3id: Signal with sample rate of 32, 44.1, 48, 88.2, 96, 176.4, or 192 kHz.

Bi-Level and Tri-Level Video: See table below.

Video Format	Video Format, continued
NTSC (“Black Burst”)	1035i/59.98 Hz
PAL (“Black Burst”)	1035i/60 Hz
525i/59.94 Hz	1080i/50 Hz
525p/59.94 Hz	1080i/59.94 Hz
625i/50 Hz	1080i/60 Hz
625p/50 Hz	1080p/23.98 Hz
720p/23.98 Hz	1080p/24 Hz
720p/24 Hz	1080p/25 Hz
720p/25 Hz	1080p/29.97 Hz
720p/29.97 Hz	1080p/30 Hz
720p/30 Hz	1080psf/24 Hz
720p/50 Hz	1080psf/23.98 Hz
720p/59.94 Hz	
720p/60 Hz	

